



# 2003 TRAIL BOSS

SERVICE MANUAL

PN 9918061

2003 TRAIL BOSS SERVICE MANUAL PN 9918061





**POLARIS**<sup>®</sup>  
The Way Out.

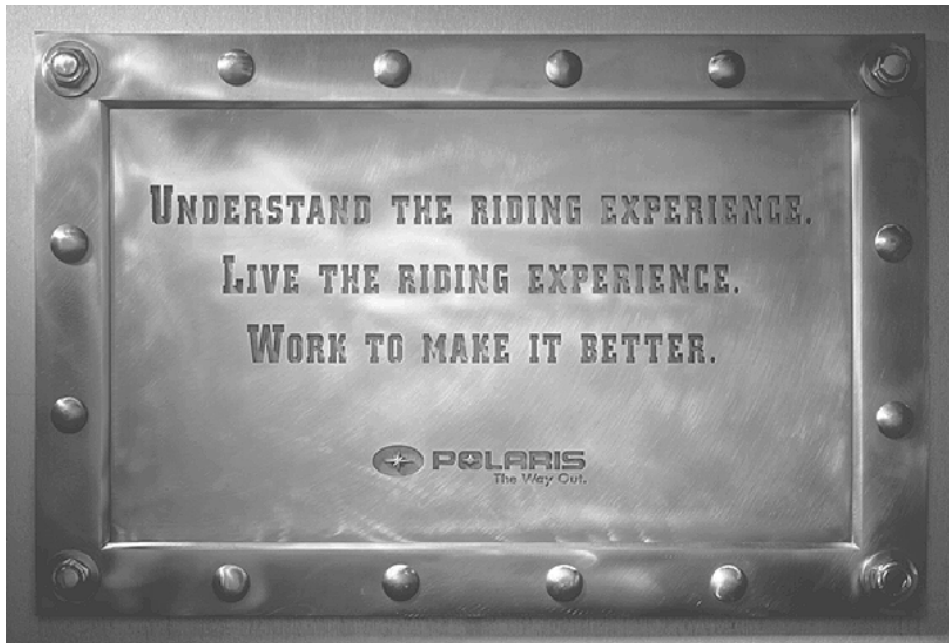

## **2003 TRAIL BOSS 330 SERVICE MANUAL**

### Foreword

This manual is designed primarily for use by certified Polaris Master Service Dealer technicians in a properly equipped shop and should be kept available for reference. All references to left and right side of the vehicle are from the operator's perspective when seated in a normal riding position.

Some procedures outlined in this manual require a sound knowledge of mechanical theory, tool use, and shop procedures in order to perform the work safely and correctly. Technicians should read the text and be familiar with service procedures before starting the work. Certain procedures require the use of special tools. Use only the proper tools as specified.

This manual includes procedures for maintenance operations, component identification and unit repair, along with service specifications for 2003 Polaris Trail Boss ATVs. Comments or suggestions about this manual may be directed to: Service Publications Dept. @ Polaris Sales Inc. 2100 Hwy 55 Medina Minnesota 55340.

### **2003 Trail Boss 330 ATV Service Manual (PN 9918061)**

©Copyright 2002 Polaris Sales Inc. All information contained within this publication is based on the latest product information at the time of publication. Due to constant improvements in the design and quality of production components, some minor discrepancies may result between the actual vehicle and the information presented in this publication. Depictions and/or procedures in this publication are intended for reference use only. No liability can be accepted for omissions or inaccuracies. Any reprinting or reuse of the depictions and/or procedures contained within, whether whole or in part, is expressly prohibited. Printed in U.S.A.

## UNDERSTANDING SAFETY LABELS AND INSTRUCTIONS

Throughout these instructions, important information is brought to your attention by the following symbols:



The Safety Alert Symbol means ATTENTION! BECOME ALERT! YOUR SAFETY IS INVOLVED!

### **DANGER**

Failure to follow DANGER instructions will result in severe injury or death to the operator, bystander or person inspecting or servicing the ATV.

### **WARNING**

Failure to follow WARNING instructions could result in severe injury or death to the operator, bystander or person inspecting or servicing the ATV.

### **CAUTION:**

A CAUTION indicates special precautions that must be taken to avoid personal injury, or ATV or property damage.

### **NOTE:**

A NOTE provides key information to clarify instructions.

## Trademarks

**Polaris acknowledges the following products mentioned in this manual:**

FLEXLOC, Registered Trademark of SPS Technologies  
Loctite, Registered Trademark of the Loctite Corporation  
STA-BIL, Registered Trademark of Gold Eagle  
FOX, Registered Trademark of Fox Shox  
Nyogel, Trademark of Wm. F. Nye Co.  
Fluke, Registered Trademark of John Fluke Mfg. Co.  
Mity Vac, Registered Trademark of Neward Enterprises, Inc.  
Ammco, Registered Trademark of Ammco Tools, Inc.  
Torx, Registered Trademark of Textron  
Hilliard, Trademark of the Hilliard Corporation

# ***CHAPTER INDEX***

<b>CHAPTER 1</b>	<b>GENERAL</b>
<b>CHAPTER 2</b>	<b>MAINTENANCE</b>
<b>CHAPTER 3</b>	<b>ENGINE</b>
<b>CHAPTER 4</b>	<b>FUEL SYSTEM</b>
<b>CHAPTER 5</b>	<b>BODY/SUSPENSION</b>
<b>CHAPTER 6</b>	<b>PVT SYSTEM</b>
<b>CHAPTER 7</b>	<b>FINAL DRIVE</b>
<b>CHAPTER 8</b>	<b>TRANSMISSION</b>
<b>CHAPTER 9</b>	<b>BRAKES</b>
<b>CHAPTER 10</b>	<b>ELECTRICAL</b>





***CHAPTER 1***  
***GENERAL INFORMATION/***  
***MAINTENANCE***

2003 Model Identification ..... 1.2  
Serial Number Location ..... 1.2  
2003 Trailboss Model ..... 1.3  
Replacement Keys ..... 1.4  
Machine Dimensions ..... 1.5  
Specifications - 2003 Trail Boss 330 ..... 1.6-1.7  
Publication Numbers ..... 1.8  
Paint Codes ..... 1.8  
Standard Torque Specifications ..... 1.8  
Tap Drill Charts ..... 1.9  
Decimal Equivalent Chart ..... 1.9  
Unit of Measure Conversion Table ..... 1.10  
Glossary of Terms ..... 1.11



## MODEL IDENTIFICATION

The machine model number must be used with any correspondence regarding warranty or service.

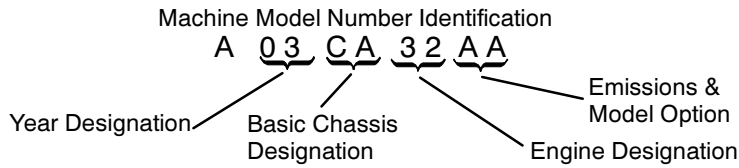

## ENGINE DESIGNATION NUMBERS

32 ES32PFE10 ..... Single, Air Cooled, SOHC 4 Stroke, Electric Start

## VIN IDENTIFICATION

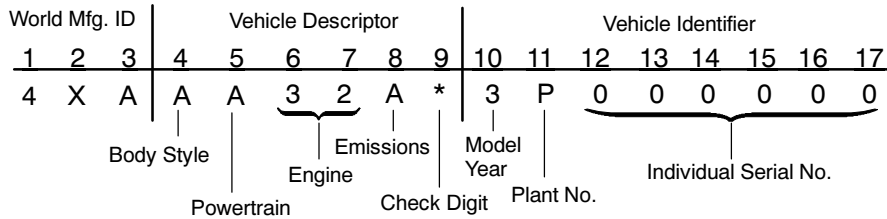

\* This could be either a number or a letter

## ENGINE SERIAL NUMBER LOCATION

Whenever corresponding about an engine, be sure to refer to the engine model number and serial number. This information can be found on the sticker applied to the recoil housing on the right side of engine.(A) An additional number is stamped on the center top of crankcase beneath the cylinder coolant elbow.

## UNIT MODEL NUMBER AND SERIAL NUMBER LOCATION

The machine model number and serial number are important for vehicle identification. The machine serial number is stamped on the lower left side of the frame tube.(B)

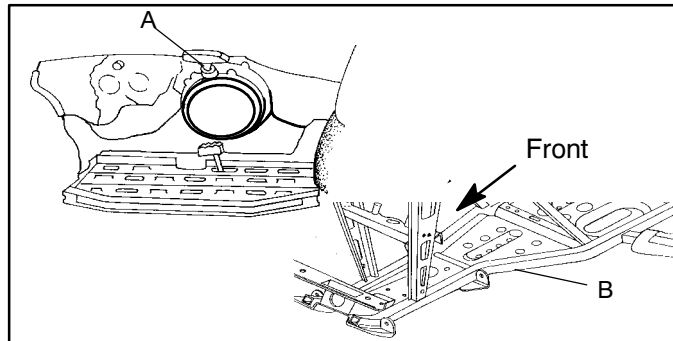

## TRANSMISSION I.D. NUMBER LOCATION

The transmission I.D. number is located on top of the transmission, right side of machine.

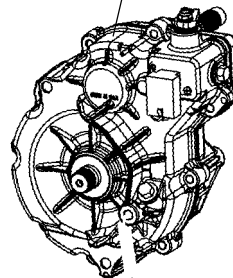



**2003 TRAILBOSS MODEL**



**2003 TRAILBOSS 330**





## REPLACEMENT KEYS

Replacement keys can be made from the original key. To identify which series the key is, take the first two digits on the original key and refer to the chart to the right for the proper part number. **Should both keys become lost, ignition switch replacement is required.**

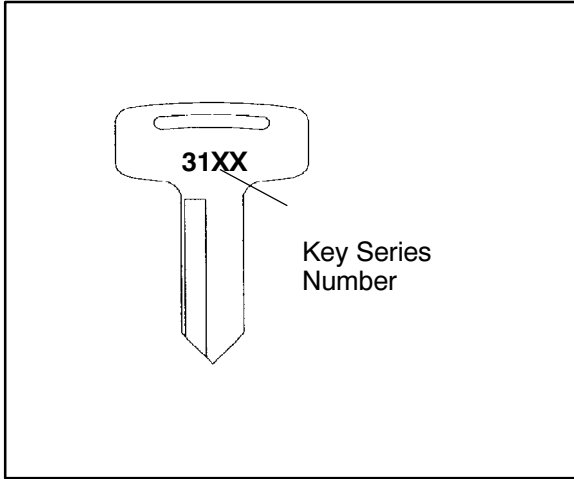

Series #	Part Number
20	4010278
21	4010278
22	4010321
23	4010321
27	4010321
28	4010321
31	4110141
32	4110148
67	4010278
68	4010278



**MACHINE DIMENSIONS**

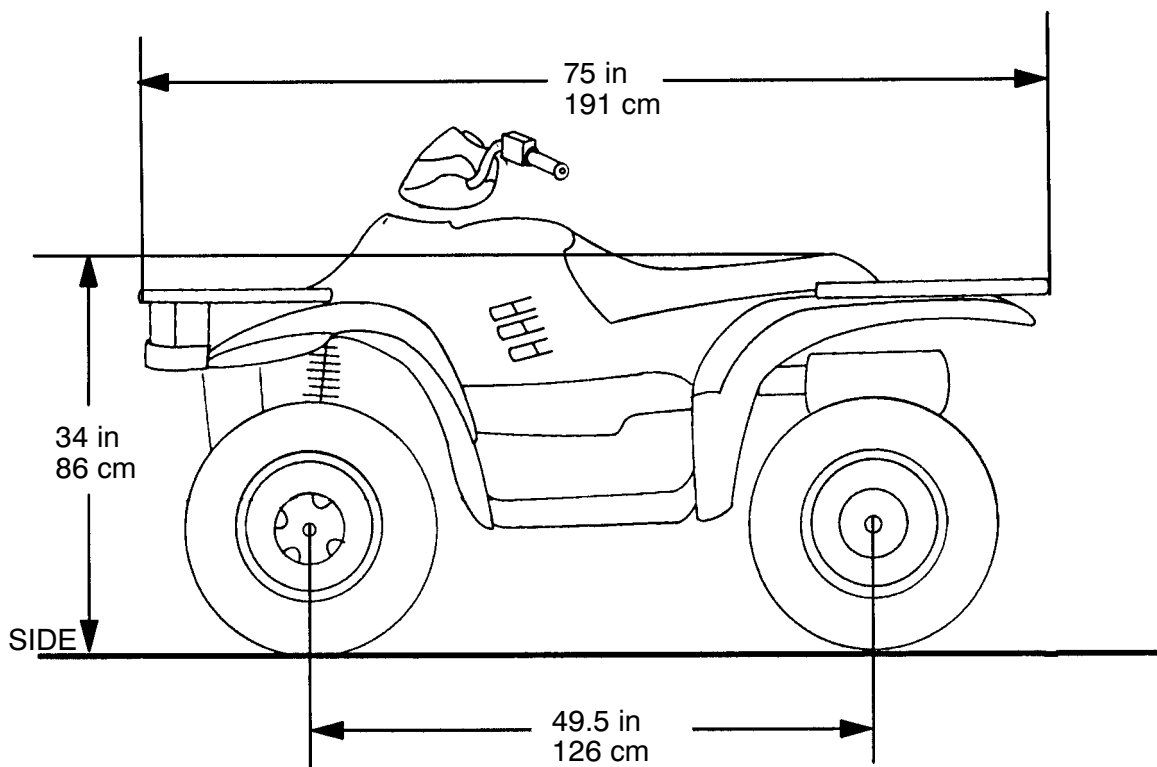
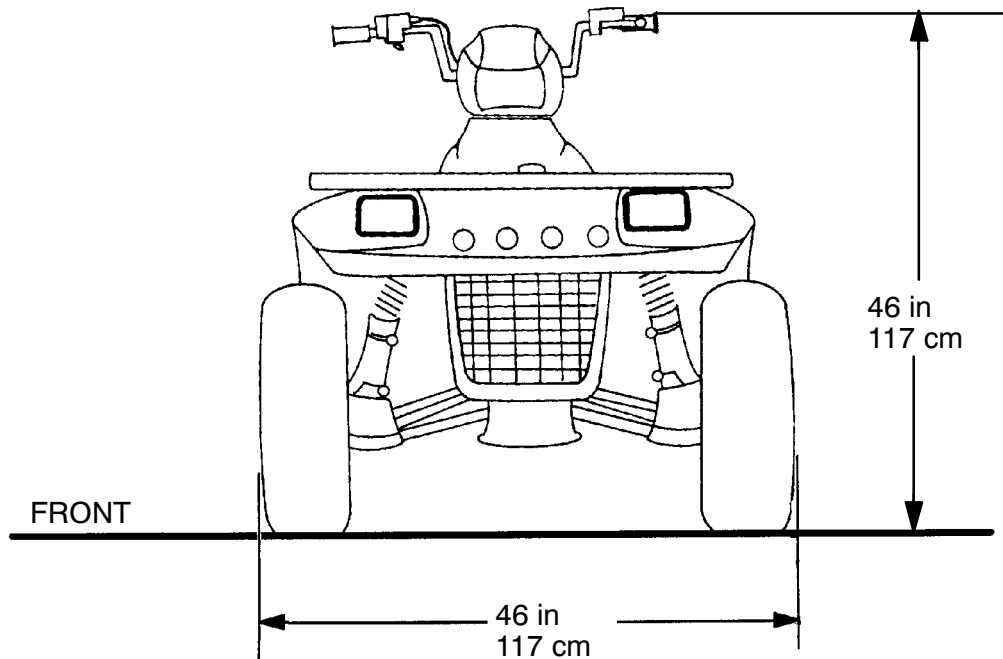



**MODEL:** ..... **2003 TRAIL BOSS 330**  
**MODEL NUMBER:** . **A03CA32**  
**ENGINE MODEL:** .. **ES32PFE10**

## CARBURETION

Type ..... BST 34 Mikuni  
Main Jet ..... 122.5  
Pilot Jet ..... 42.5  
Jet Needle ..... 4HB48-2  
Needle Jet ..... P-0M  
Pilot Screw ..... 2 Turns Out  
Pilot Air Jet ..... 160  
Valve Seat ..... 1.5  
Fuel Octane (R+M/2) . 87 Non-Oxygenated or  
89 Oxygenated

## JETTING CHART

Altitude		AMBIENT TEMPERATURE	
		Below 40°F Below 5°C	+40°F to +80°F +5°C to +26°C
Meters (Feet)	0-1800 (0-6000)	117.5	122.5
	above 1800 (above 6000)	120	115

## CLUTCH

Type ..... PVT  
Belt ..... 3211077  
Belt Width (Projected) ..... 1.188" (30.18mm)  
Side Angle (Overall) ..... 26°  
Outside Circumference ..... 40.86 ±.12"  
Center Distance ..... 10±.12" (254.5mm)  
Clutch Offset ..... 0.5" (12.7mm)  
Drive Spring ..... Grey  
Driven Spring ..... Black  
Driven Helix ..... 2+2

## CLUTCH CHART

Altitude		Shift Weight	Drive Clutch Spring	Driven Clutch Spring	Driven Helix
Meters (Feet)	0-1800 (0-6000)	20-40	Blue/Grey	Black	2+2
	1800-3700 (6000-12000)	20-38	Blue/Grey	Black	2+2

\* 40° helix, black driven spring

## ENGINE

Type ..... 4 Cycle, Single Cyl.  
Displacement ..... 329 cc  
Bore ..... 3.091" (78.5mm)  
Stroke ..... 2.679" (68mm)  
Valve Clearance In & Ex ..... 0.006 ± 0.0008" (0.15 ± 0.02 mm) BTDC on compression  
Cooling ..... Air with fan assisted oil cooler  
Lubrication Type ..... Wet Sump  
Piston Marking ..... None  
Operating RPM±200 ..... 6300 RPM  
Idle RPM ± 50 (lights off) ..... 1300 RPM  
Compression Ratio ..... 9.2:1  
Compression Pressure ..... 70-90 PSI



**MODEL:** ..... **2003 TRAIL BOSS 330**  
**MODEL NUMBER:** ... **A03CA32**  
**ENGINE MODEL:** .... **ES32PFE10**

**ELECTRICAL**

Flywheel I.D. .... None  
 CDI Part Number ... 4010697  
 Alternator Output ... 210 watts  
 Ignition Timing .... 30°±2° BTDC@5000RPM  
 Spark Plug / Gap ... NGK BKR6E / 0.036" (0.9 mm)  
 Lights: Head .... (2) Dual Beam 30/30 watts  
     Tail ..... 8.26 watts  
     Brake ..... 26.9 watts  
     Indicator ... 1.0 watts  
 Electric Start ..... Standard  
 Electronic Speedo .. N/A

**FLUID**

**Capacity    Type**

Fuel Tank ..... 3.25 gals. (12.30 L)  
 Transmission ..... 11.3 oz. (335 ml) PPS\*  
 Engine Oil ..... 1.5 qts (1.4 L) PP4\*  
 Brake (Hand) ..... Dot 3  
 Brake (Foot) ..... Dot 3

**SUSPENSION / CHASSIS**

Body Style ..... Gen IV  
 Front Suspension .. MacPherson Strut  
 Tow Capacity ..... 850 lbs. (385.9 kg)  
 Turning Radius .... 75" (191 cm)  
 Toe Out ..... 1/8"-1/4" (3-6.35 mm)  
 Ground Clearance .. 5.5" (13.97 cm)  
 Front Vertical Travel 6.7" (17.02 cm)  
 Rear Suspension ... Progressive Rate Swing Arm  
 Rear Travel ..... 9.0" (22.86 cm)  
 Rear Shock ..... 2" Gas Charged Twin Tube  
 Shock Adjustment .. Cam

**TIRES**

Tire Size - Front .... 23 x 7 - 10  
 Tire Size - Rear .... 22 x 11 - 10  
 Tire Pressure - F/R . 4/3 lbs.  
 Total Width ..... 46" (117 cm)  
 Total Length ..... 75" (191 cm)  
 Total Height ..... 46" (117 cm)  
 Wheel Base ..... 49.5" (125.73 cm)  
 Weight - Dry ..... 505 lbs. (230 kg)

**OPTIONAL SUSPENSION SPRINGS**

<b>SPRING TYPE</b>	<b>SOFT</b>	<b>STANDARD</b>	<b>FIRM</b>
Rear Compression Spring	N / A	<b>7041518-067</b> 130 -165 lb/in.	<b>7041303-067</b> 250 lb/in.
Front Strut Spring	N / A	<b>7041850-067</b> 41 lb/in.	<b>7041375-067</b> 64 - 113 lb/in.

**Polaris Lubricants**

\*PP6 Polaris Premium 60/40 Antifreeze/Coolant  
 \*PPS Polaris Premium Synthetic Gear Case Oil  
 \*PP4 Polaris 0W-40 Synthetic Engine Lubricant  
 \*PDD Premium Demand Drive Hub Fluid

**DRIVE TRAIN**

Chain Type ..... 520 O-Ring  
 Gear Reduction-Rev . 3.05/1  
 Gear Reduction-High 2.68/1  
 Final Drive Ratio .... 11/40 78P  
 Brake (Hand) ..... Single Lever, Hyd. Disc  
 Brake ( Auxiliary Foot) Hydraulic

**LOAD CAPACITY**

Front Rack (Accy) .... 75 lbs. (34 kg)  
 Rear Rack (Std) ..... 125 lbs. (57 kg)  
 Tongue Weight ..... 85 lbs. (14 kg)  
 Tow Hitch ..... Std



**PUBLICATION NUMBERS**

Year	Model	Model No.	Owner's Manual PN	Parts Manual PN	Parts Micro Fiche PN
2003	Trail Boss 330	A03CA32AA	9917492	9917862	9917863

**NOTE:** When ordering service parts be sure to use the correct parts manual.

**PAINT CODES**

PAINTED PART	COLOR DESCRIPTION	DITZLER NUMBER	POLARIS NUMBER
Springs	Silver	--	P-385
Rims	Bright White	2185	P-133
Rack(s)	Black	9440	P-067
Frame	Black	9440	P-067

FRAME COLOR - P067 Medium Gloss Black 9440 / 8520147.

Order direct from Midwest Industrial Coatings 952-252-2000 See Quick Reference Manual for ordering info.

**STANDARD TORQUE SPECIFICATIONS**

The following torque specifications are to be used as a general guideline. **FOR SPECIFIC TORQUE VALUES OF FASTENERS Refer to exploded views in the appropriate section.** There are exceptions in the steering, suspension, and engine sections.

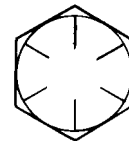
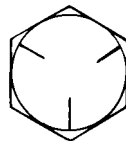
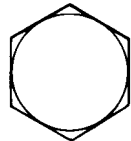

Bolt Size	Threads/In	Grade 2	Grade 5	Grade 8
<b><u>Torque in. lbs. (Nm)</u></b>				
#10	- 24	27 (3.1)	43 (5.0)	60 (6.9)
#10	- 32	31 (3.6)	49 (5.6)	68 (7.8)
<b><u>Torque ft. lbs. (Nm)*</u></b>				
1/4	- 20	5 (7)	8 (11)	12 (16)
1/4	- 28	6 (8)	10 (14)	14 (19)
5/16	- 18	11 (15)	17 (23)	25 (35)
5/16	- 24	12 (16)	19 (26)	29 (40)
3/8	- 16	20 (27)	30 (40)	45 (62)
3/8	- 24	23 (32)	35 (48)	50 (69)
7/16	- 14	30 (40)	50 (69)	70 (97)
7/16	- 20	35 (48)	55 (76)	80 (110)
1/2	- 13	50 (69)	75 (104)	110 (152)
1/2	- 20	55 (76)	90 (124)	120 (166)

**Metric / Torque**

6 x 1.0    72-78 In. lbs.    8 x 1.25    14-18 ft. lbs.    10 x 1.25    26-30 ft. lbs.



**SAE TAP DRILL SIZES**

Thread Size/Drill Size		Thread Size/Drill Size	
#0-80	3/64	1/2-13	27/64
#1-64	53	1/2-20	29/64
#1-72	53	9/16-12	31/64
#2-56	51	9/16-18	33/64
#2-64	50	5/8-11	17/32
#3-48	5/64	5/8-18	37/64
#3-56	45	3/4-10	21/32
#4-40	43	3/4-16	11/16
#4-48	42	7/8-9	49/64
#5-40	38	7/8-14	13/16
#5-44	37	1-8	7/8
#6-32	36	1-12	59/64
#6-40	33	1 1/8-7	63/64
#8-32	29	1 1/8-12	1 3/64
#8-36	29	1 1/4-7	1 7/64
#10-24	24	1 1/4-12	1 11/64
#10-32	21	1 1/2-6	1 11/32
#12-24	17	1 1/2-12	1 27/64
#12-28	4.6mm	1 3/4-5	1 9/16
1/4-20	7	1 3/4-12	1 43/64
1/4-28	3	2-4 1/2	1 25/32
5/16-18	F	2-12	1 59/64
5/16-24	I	2 1/4-4 1/2	2 1/32
3/8-16	O	2 1/2-4	2 1/4
3/8-24	Q	2 3/4-4	2 1/2
7/16-14	U	3-4	2 3/4
7/16-20	25/64		

**DECIMAL EQUIVALENTS**

1/64	.....	.0156	
1/32	.....	.0312	... 1 mm = .0394"
3/64	.....	.0469	
1/16	.....	.0625	
5/64	.....	.0781	... 2 mm = .0787"
3/32	.....	.0938	
7/64	.....	.1094	... 3 mm = .1181"
1/8	.....	.1250	
9/64	.....	.1406	
5/32	.....	.1563	... 4 mm = .1575"
11/64	.....	.1719	
3/16	.....	.1875	... 5 mm = .1969"
13/64	.....	.2031	
7/32	.....	.2188	
15/64	.....	.2344	... 6 mm = .2362"
1/4	.....	.25	
17/64	.....	.2656	... 7 mm = .2756"
9/32	.....	.2813	
19/64	.....	.2969	
5/16	.....	.3125	... 8 mm = .3150"
21/64	.....	.3281	
11/32	.....	.3438	... 9 mm = .3543"
23/64	.....	.3594	
3/8	.....	.375	
25/64	.....	.3906	... 10 mm = .3937"
13/32	.....	.4063	
27/64	.....	.4219	... 11 mm = .4331"
7/16	.....	.4375	
29/64	.....	.4531	
15/32	.....	.4688	... 12 mm = .4724"
31/64	.....	.4844	
1/2	.....	.5	... 13 mm = .5118
33/64	.....	.5156	
17/32	.....	.5313	
35/64	.....	.5469	... 14 mm = .5512"
9/16	.....	.5625	
37/64	.....	.5781	... 15 mm = .5906"
19/32	.....	.5938	
39/64	.....	.6094	
5/8	.....	.625	... 16 mm = .6299"
41/64	.....	.6406	
21/32	.....	.6563	... 17 mm = .6693"
43/64	.....	.6719	
11/16	.....	.6875	
45/64	.....	.7031	... 18 mm = .7087"
23/32	.....	.7188	
47/64	.....	.7344	... 19 mm = .7480"
3/4	.....	.75	
49/64	.....	.7656	
25/32	.....	.7813	... 20 mm = .7874"
51/64	.....	.7969	
13/16	.....	.8125	... 21 mm = .8268"
53/64	.....	.8281	
27/32	.....	.8438	
55/64	.....	.8594	... 22 mm = .8661"
7/8	.....	.875	
57/64	.....	.8906	... 23 mm = .9055"
29/32	.....	.9063	
59/64	.....	.9219	
15/16	.....	.9375	... 24 mm = .9449"
61/64	.....	.9531	
31/32	.....	.9688	... 25 mm = .9843
63/64	.....	.9844	
1	.....	1.0	

**METRIC TAP DRILL SIZES**

Tap Size	Drill Size	Decimal Equivalent	Nearest Fraction
3 x .50	#39	0.0995	3/32
3 x .60	3/32	0.0937	3/32
4 x .70	#30	0.1285	1/8
4 x .75	1/8	0.125	1/8
5 x .80	#19	0.166	11/64
5 x .90	#20	0.161	5/32
6 x 1.00	#9	0.196	13/64
7 x 1.00	16/64	0.234	15/64
8 x 1.00	J	0.277	9/32
8 x 1.25	17/64	0.265	17/64
9 x 1.00	5/16	0.3125	5/16
9 x 1.25	5/16	0.3125	5/16
10 x 1.25	11/32	0.3437	11/32
10 x 1.50	R	0.339	11/32
11 x 1.50	3/8	0.375	3/8
12 x 1.50	13/32	0.406	13/32
12 x 1.75	13/32	0.406	13/32

**CONVERSION TABLE**

Unit of Measure	Multiplied by	Converts to
ft. lbs.	x 12	= in. lbs.
in. lbs.	x .0833	= ft. lbs.
ft. lbs.	x 1.356	= Nm
in. lbs.	x .0115	= kg-m
Nm	x .7376	= ft.lbs.
kg-m	x 7.233	= ft. lbs.
kg-m	x 86.796	= in. lbs.
kg-m	x 10	= Nm
in.	x 25.4	=mm
mm	x .03937	= in.
in.	x 2.54	= cm
mile (mi.)	x 1.6	= km
km	x .6214	= mile (mi.)
Ounces (oz)	x 28.35	= Grams (g)
Fluid Ounces (fl. oz.)	x 29.57	= Cubic Centimeters (cc)
Cubic Centimeters (cc)	x .03381	= Fluid Ounces (fl. oz.)
Grams (g)	x 0.035	= Ounces (oz)
lb.	x .454	= kg
kg	x 2.2046	= lb.
Cubic inches (cu in)	x 16.387	= Cubic centimeters (cc)
Cubic centimeters (cc)	x 0.061	= Cubic inches (cu in)
Imperial pints (Imp pt)	x 0.568	= Liters (l)
Liters (l)	x 1.76	= Imperial pints (Imp pt)
Imperial quarts (Imp qt)	x 1.137	= Liters (l)
Liters (l)	x 0.88	= Imperial quarts (Imp qt)
Imperial quarts (Imp qt)	x 1.201	= US quarts (US qt)
US quarts (US qt)	x 0.833	= Imperial quarts (Imp qt)
US quarts (US qt)	x 0.946	= Liters (l)
Liters (l)	x 1.057	= US quarts (US qt)
US gallons (US gal)	x 3.785	=Liters (l)
Liters (l)	x 0.264	= US gallons (US gal)
Pounds - force per square inch (psi)	x 6.895	= Kilopascals (kPa)
Kilopascals (kPa)	x 0.145	= Pounds - force per square inch (psi)
Kilopascals (kPa)	x 0.01	= Kilograms - force per square cm
Kilograms - force per square cm	x 98.1	= Kilopascals (kPa)
$\pi (3.14) \times R^2 \times H$ (height)		= Cylinder Volume

°C to °F:  $9 (°C + 40) \div 5 - 40 = °F$

°F to °C:  $5 (°F + 40) \div 9 - 40 = °C$



## GLOSSARY OF TERMS

**ABDC:** After bottom dead center.

**ACV:** Alternating current voltage.

**Alternator:** Electrical generator producing voltage alternating current.

**ATDC:** After top dead center.

**BBDC:** Before bottom dead center.

**BDC:** Bottom dead center.

**BTDC:** Before top dead center.

**CC:** Cubic centimeters.

**Center Distance:** Distance between center of crankshaft and center of driven clutch shaft.

**Chain Pitch:** Distance between chain link pins (No. 35 = 3/8" or 1 cm). Polaris measures chain length in number of pitches.

**CI:** Cubic inches.

**Clutch Buttons:** Plastic bushings which aid rotation of the movable sheave in the drive and driven clutch.

**Clutch Offset:** Drive and driven clutches are offset so that drive belt will stay nearly straight as it moves along the clutch face.

**Clutch Weights:** Three levers in the drive clutch which relative to their weight, profile and engine RPM cause the drive clutch to close and grip the drive belt.

**Crankshaft Run-Out:** Run-out or "bend" of crankshaft measured with a dial indicator while crankshaft is supported between centers on V blocks or resting in crankcase. Measure at various points especially at PTO.

**DCV:** Direct current voltage.

**Dial Bore Gauge:** A cylinder measuring instrument which uses a dial indicator. Good for showing taper and out-of-round in the cylinder bore.

**Electrical Open:** Open circuit. An electrical circuit which isn't complete.

**Electrical Short:** Short circuit. An electrical circuit which is completed before the current reaches the intended load. (i.e. a bare wire touching the chassis).

**End Seals:** Rubber seals at each end of the crankshaft.

**Engagement RPM:** Engine RPM at which the drive clutch engages to make contact with the drive belt.

**ft.:** Foot/feet.

**Foot Pound:** Ft. lb. A force of one pound at the end of a lever one foot in length, applied in a rotational direction.

**g:** Gram. Unit of weight in the metric system.

**gal.:** Gallon.

**ID:** Inside diameter.

**in.:** Inch/inches.

**Inch Pound:** In. lb. 12 in. lbs. = 1 ft. lb.

**kg/cm<sup>2</sup>:** Kilograms per square centimeter.

**kg-m:** Kilogram meters.

**Kilogram/meter:** A force of one kilogram at the end of a lever one meter in length, applied in a rotational direction.

**l or ltr:** Liter.

**lbs/in<sup>2</sup>:** Pounds per square inch.

**Left or Right Side:** Always referred to based on normal operating position of the driver.

**m:** Meter/meters.

**Mag:** Magneto.

**Magnetic Induction:** As a conductor (coil) is moved through a magnetic field, a voltage will be generated in the windings. Mechanical energy is converted to electrical energy in the stator.

**mi.:** Mile/miles.

**mm:** Millimeter. Unit of length in the metric system. 1mm = approximately .040".

**Nm:** Newton meters.

**OD:** Outside diameter.

**Ohm:** The unit of electrical resistance opposing current flow.

**oz.:** Ounce/ounces.

**Piston Clearance:** Total distance between piston and cylinder wall.

**psi.:** Pounds per square inch.

**PTO:** Power take off.

**PVT:** Polaris Variable Transmission (Drive Clutch System)

**qt.:** Quart/quarts.

**Regulator:** Voltage regulator. Regulates battery charging system output at approx. 14.5 DCV as engine RPM increases.

**Reservoir Tank:** The fill tank in the liquid cooling system.

**Resistance:** In the mechanical sense, friction or load. In the electrical sense, ohms, resulting in energy conversion to heat.

**RPM:** Revolutions per minute.

**Seized Piston:** Galling of the sides of a piston. Usually there is a transfer of aluminum from the piston onto the cylinder wall. Possible causes: 1) improper lubrication; 2) excessive temperatures; 3) insufficient piston clearance; 4) stuck piston rings.

**Stator Plate:** The plate mounted under the flywheel supporting the battery charging coils.

**TDC:** Top dead center. Piston's most outward travel from crankshaft.

**Volt:** The unit of measure for electrical pressure of electromotive force. Measured by a voltmeter in parallel with the circuit.

**Watt:** Unit of electrical power. Watts = amperes x volts.

**WOT:** Wide open throttle.









**CHAPTER 2**  
**MAINTENANCE**

Periodic Maintenance Chart ..... 2.2-2.3

Pre-Ride Inspection ..... 2.3

Recommended Maintenance Products ..... 2.4

Lubricant and Maintenance Quick Reference 2.5-2.6

Special Tools ..... 2.7

Transmission Lubrication ..... 2.8

Transmission Linkage Adjustment ..... 2.9

Throttle Operation / Choke Adjustment ..... 2.10

Carburetor Adjustments ..... 2.10-2.11

ETC Switch Adjustment ..... 2.11

Fuel System ..... 2.12

Compression Test ..... 2.13

Battery Maintenance ..... 2.13-2.14

Electrical ..... 2.14-2.15

Oil Cooler Maintenance ..... 2.15

Air Filter Service ..... 2.15

Air Box Sediment Tube Service ..... 2.16

Breather Filter ..... 2.16

Recoil Housing/PVT Drying ..... 2.16-2.17

Oil Level/Change/Filter ..... 2.17-2.18

Valve Clearance ..... 2.19-2.20

Steering and Toe Alignment ..... 2.20-2.22

Exhaust System Maintenance ..... 2.22

Brake System Service ..... 2.23-2.24

Drive Chain and Sprocket Service ..... 2.24-2.26

Suspension Service / Controls ..... 2.26-2.27

Wheel Removal / Installation ..... 2.27

Tire Inspection ..... 2.28





## PERIODIC MAINTENANCE CHART

Inspection, adjustment and lubrication intervals of important components is listed in the following chart. Maintenance intervals are based upon average riding conditions and a vehicle speed of approximately 10 mph. Inspect, clean, lubricate, adjust or replace parts as necessary. **NOTE:** Inspection may reveal the need for replacement parts. Always use genuine Polaris parts.

■ = **CAUTION: Due to the nature of these adjustments, it is recommended that service be performed by an authorized Polaris dealer.**

▶ = **Vehicles subjected to severe use (operation in wet or dusty areas, low speed heavy load operation, prolonged idle) should be inspected and serviced more frequently. For engine oil, short trip cold weather riding also constitutes severe use.** Pay special attention to oil level. A rise in oil level in cold weather can indicate moisture collecting in the oil tank. Change oil immediately if oil level begins to rise.

E = **Emission Control System Service (California).**

	Item	Frequency (Whichever comes first)			Remarks
		Hours	Calendar	Miles (Km)	
E▶	Engine Oil - Level/Change	100 hrs	6 months	1000 (1600)	Check Level Daily; Break In service at 1 month
E	Oil Filter	100 hrs	6 months	1000 (1600)	Replace with oil change
E▶	Air Filter - Foam Pre-Cleaner	Daily	Daily		Inspect-Clean & oil more often in dirty conditions.
E▶	Air Filter - Main Element	Weekly	Weekly		Inspect - Replace if necessary
▶	Air Box Sediment Tube	-	Daily		Drain deposits whenever visible
▶	Engine Breather Filter	20 hrs	Monthly	200 (320)	Inspect and replace if necessary
▶	Oil Tank Vent Hose	100 hrs	12 months	1000 (1600)	Inspect hose routing /hose condition
E■	Valve Clearance	100 hrs	12 months	1000 (1600)	Inspect/Adjust
E	Idle Speed	As required	As required		Adjust
■	Throttle Cable / ETC Switch	50 hrs	6 months	500 (800)	Inspect -Adjust, Lubricate, Replace if necessary
	Choke (Enricher) Cable	50 hrs	6 months	500 (800)	Inspect -Adjust, Lubricate, Replace if necessary
	Carburetor Float Bowl	50 hrs	6 months	500 (800)	Drain bowl periodically and prior to storage
	Carburetor Air Intake Ducts/Flange	50 hrs	6 months	500 (800)	Inspect all ducts for proper sealing/air leaks
E■	Fuel System	100 hrs	12 months	1000 (1600)	Check for leaks at tank cap, lines, fuel valve, filter, pump & carburetor. Replace lines every 2 years.
E■	Fuel Filter	100 hrs	12 months	1000 (1600)	Replace filter annually
	Coolant/Level Inspection	Daily	Daily		Replace engine coolant every 2 years
	Coolant Strength / Pressure Test System	100 hrs	6 months	1000 (1600)	Inspect strength seasonally; Pressure test system annually
	Radiator	100 hrs	12 months	1000 (1600)	Inspect / Clean external surface
	Cooling System Hoses	100 hrs	12 months	1000 (1600)	Inspect
	Engine Mounts	100 hrs	12 months	1000 (1600)	Inspect
	Drain Recoil Housing	Weekly	Weekly		More often if operating in wet environment
	Exhaust Muffler / Pipe	100 hrs	12 months	1000 (1600)	
<b>ELECTRICAL</b>					
E	Spark Plug	100 hrs	12 months	1000 (1600)	Inspect - Replace if necessary
	Wiring	100 hrs	12 months	1000 (1600)	Inspect for abrasion, routing, security
	Ignition Timing	100 hrs	12 months	1000 (1600)	Inspect
	Battery	20 hrs	Monthly	200 (320)	Check terminals; Clean; Check fluid level
	Headlight Aim	As required	As required		Adjust if Necessary
	Headlamp Inspection	Daily	Daily		Check operation daily; Apply Nyogel™ Grease to connector when lamp is replaced
	Tail Lamp Inspection	Daily	Daily		Check Operation Daily; Apply Nyogel™ Grease to socket when lamp is replaced



**PERIODIC MAINTENANCE CHART, CONT.**

<b>CHASSIS</b>					
	<b>Item</b>	<b>Frequency (Whichever comes first)</b>			<b>Remarks</b>
		<b>Hours</b>	<b>Calendar</b>	<b>Miles (Km)</b>	
▶	General Lubrication	50 hrs	3 months	500 (800)	Lubricate All Fittings, Pivots, Cables, Etc.
▶	Front Hubs/Fluid Check	50 hrs	6 months	500 (800)	Check monthly
▶	Front Hubs/Fluid Change	100 hrs	12 months	1000 (1600)	Check monthly
▪	Front Wheel Bearings (2x4)	Annually	12 months		Inspect and replace if necessary
▪	Front Hub Spindle Nut Torque (AWD Models)	Annually	12 months		Inspect Torque and Locking Fastener and replace if necessary
	Drive Belt	50 hrs	6 months	500 (800)	Inspect - Adjust, Replace if Necessary
	Clutches (Drive And Driven)	100 hrs	12 months	1000 (1600)	Inspect, Clean
▶	Transmission Oil Level	25 hrs	Monthly	250 (400)	Inspect Monthly; Change Annually
	Shift Linkage	50 hrs	6 months	500 (800)	Inspect, Lubricate, Adjust
▪	Steering	50 hrs	6 months	500 (800)	Inspect Daily, Lubricate
▪	Toe Adjustment	As required	As required		Periodic Inspection, Adjust When Parts are Replaced
▶	Rear Axle	50 hrs	6 months	500 (800)	Inspect Bearings, Grease Fitting
▶	Front Suspension	50 hrs	6 months	500 (800)	Inspect - Lubricate
▶	Rear Suspension	50 hrs	6 months	500 (800)	Inspect - Lubricate
	Drive Chain	50 hrs	6 months	500 (800)	Inspect Daily, Adjust and Lubricate if Needed
	Tires	Pre-ride	Pre-ride		Inspect Daily, Pre-Ride Inspection Item
▪	Brake Fluid	200 hrs	24 months	2000 (3200)	Change Every Two Years
▶	Brake Fluid Level	Pre-ride	Pre-ride		Inspect Daily, Pre-Ride Inspection Item
▶	Brake Lever Travel	Pre-ride	Pre-ride		Inspect Daily, Pre-Ride Inspection Item
▪	Brake Pad Wear	10 hrs	Monthly	100 (160)	Inspect Periodically
	Auxiliary Brake Adjustment	As required	As required		Inspect Deflection Daily; Adjust
	Output Shaft Bearing	Monthly	Monthly		Grease Monthly
	Brake System	Pre-ride	Pre-ride		Pre-Ride Inspection Item
	Wheels	Pre-ride	Pre-ride		Pre-Ride Inspection Item
	Frame Nuts, Bolts, Fasteners	Pre-ride	Pre-ride		Pre-Ride Inspection Item

**PRE-RIDE / DAILY INSPECTION**

Perform the following pre-ride inspection daily, and when servicing the vehicle at each scheduled maintenance.

- Tires - check condition and pressures
- Fuel and oil tanks - fill both tanks to their proper level; Do not overfill oil tank
- All brakes - check operation and adjustment (includes auxiliary brake)
- Throttle - check for free operation and closing
- Headlight/Taillight/Brakelight - check operation of all indicator lights and switches
- Engine stop switch - check for proper function
- Wheels - check for tightness of wheel nuts and axle nuts; be sure axle nuts are secured by cotter pins
- Drive chain - condition and slack; refer to drive chain adjustment
- Air cleaner element - check for dirt; clean or replace
- Steering - check for free operation noting any unusual looseness in any area
- Loose parts - visually inspect vehicle for any damaged or loose nuts, bolts or fasteners
- Engine coolant - check for proper level at the recovery bottle

**POLARIS LUBRICANTS, MAINTENANCE AND SERVICE PRODUCTS**

Part No.	Description
<b>Engine Lubricant</b>	
2870791	Fogging Oil (12 oz. Aerosol)
2871281	Engine Oil (Quart) Premium 4 Synthetic 0W-40 (4-Cycle) (12 Count)
2871844	Engine Oil (Gallon) Premium 4 Synthetic 0W-40 (4-Cycle) (4 Count)
2871567	Engine Oil (16 Gallon) Premium 4 Synthetic 0W-40 (4-Cycle)
<b>Gearcase / Transmission Lubricants</b>	
2873603	Premium Synthetic Gearcase Lubricant (1 Gal.) (4 Count)
2873602	Premium Synthetic Gearcase Lubricant (12 oz. bottle) (12 Count)
2871653	Premium Front Gearcase Fluid (8 oz.) (12 Count)
2871653	Premium Front Gearcase Fluid (2.5 Gal) (2 Count)
2870465	Oil Pump for 1 Gallon Jug
2871654	Premium Drive Hub Fluid (8 oz.) (12 Count)
2872277	Premium Drive Hub Fluid (2.5 gal.) (2 Count)
2871653	Angle Drive Fluid (8 oz.)
<b>Grease / Specialized Lubricants</b>	
2871322	Premium All Season Grease (3 oz. cartridge) (24 Count)
2871423	Premium All Season Grease (14 oz. cartridge) (10 Count)
2871460	Starter Drive Grease (12 Count)
2871515	Premium U-Joint Lube (3 oz.) (24 Count)
2871551	Premium U-Joint Lube (14 oz.) (10 Count)
2871312	Grease Gun Kit
2871329	Dielectric Grease (Nyogel™)
<b>Coolant</b>	
2871323	60/40 Coolant (Gallon) (6 Count)
2871534	60/40 Coolant (Quart) (12 Count)
<b>Additives / Sealants / Thread Locking Agents / Misc.</b>	
2870585	Loctite™ Primer N, Aerosol, 25 g
2871956	Loctite™ Thread Sealant 565 (50 ml.) (6 Count)
2871949	Loctite™ Threadlock 242 (50 ml.) (10 Count)
2871950	Loctite™ Threadlock 242 (6 ml.) (12 Count)
2871951	Loctite™ Threadlock 262 (50 ml.) (10 Count)
2871952	Loctite™ Threadlock 262 (6 ml.) (12 Count)
2871953	Loctite™ Threadlock 271 (6 ml.) (12 Count)
2871954	Loctite™ Threadlock 271 (36 ml.) (6 Count)

2870584	Loctite™ 680-Retaining Compound (10 ml.)
2870587	Loctite™ 518 Gasket Eliminator / Flange Sealant (50 ml.) (10 Count)
2872113	Disk Brake Quiet (12 oz.) (12 Count)
2871326	Premium Carbon Clean (12 oz.) (12 Count)
2870652	Fuel Stabilizer (16 oz.) (12 Count)
2871957	Black RTV Silicone Sealer (3 oz. tube) (12 Count)
2871958	Black RTV Silicone Sealer (11 oz. cartridge) (12 Count)
2870990	DOT3 Brake Fluid (12 Count)
2872113	Disc Brake Quiet, Aerosol, (9 oz.) (12 Count)
2871557	Crankcase Sealant, 3-Bond 1215 (5oz.)
2872893	Engine Degreaser (12oz.) (12 Count)

**NOTE:** The number count indicated by each part number in the table above indicates the number of units that are shipped with each order.

**NOTE:** Each item can be purchased separately at your local Polaris dealer.



## **RECOMMENDED MAINTENANCE PRODUCTS - QUICK REFERENCE**

Item	Type	Notes	See Pages
Engine Oil	Polaris Premium 4 Synthetic, 0W-40	Add to proper level on dipstick.	2.17-2.18
Transmission	Polaris Synthetic Gear Case Lubricant	Refer to procedures outlined later in this chapter.	2.8
Brake Fluid	Polaris DOT 3 Brake Fluid	Fill to indicated level inside reservoir.	2.23

## **MAINTENANCE QUICK REFERENCE**

III. #	Item	Lube Rec.	Method	Frequency*
1	Engine Oil	Polaris 0W-40 Synthetic	Add oil to proper level.	Change after 1st month, 6 months or 100 hours thereafter; Change more often (25-50 hours) in extremely dirty conditions, or short trip cold weather operation.
2	Transmission	Polaris Synthetic Gear Case Lubricant	Add lube to FULL level on dipstick.	Change annually ☑
3	Brake Fluid	Polaris DOT 3 Brake Fluid	Fill master cylinder reservoir to indicated level inside reservoir. See Page 2.23.	As required. Change fluid every 2 years.
4	Drive Chain	Polaris Chain Lube or O-Ring chain lube	Apply to chain link plates and rollers.	As required*

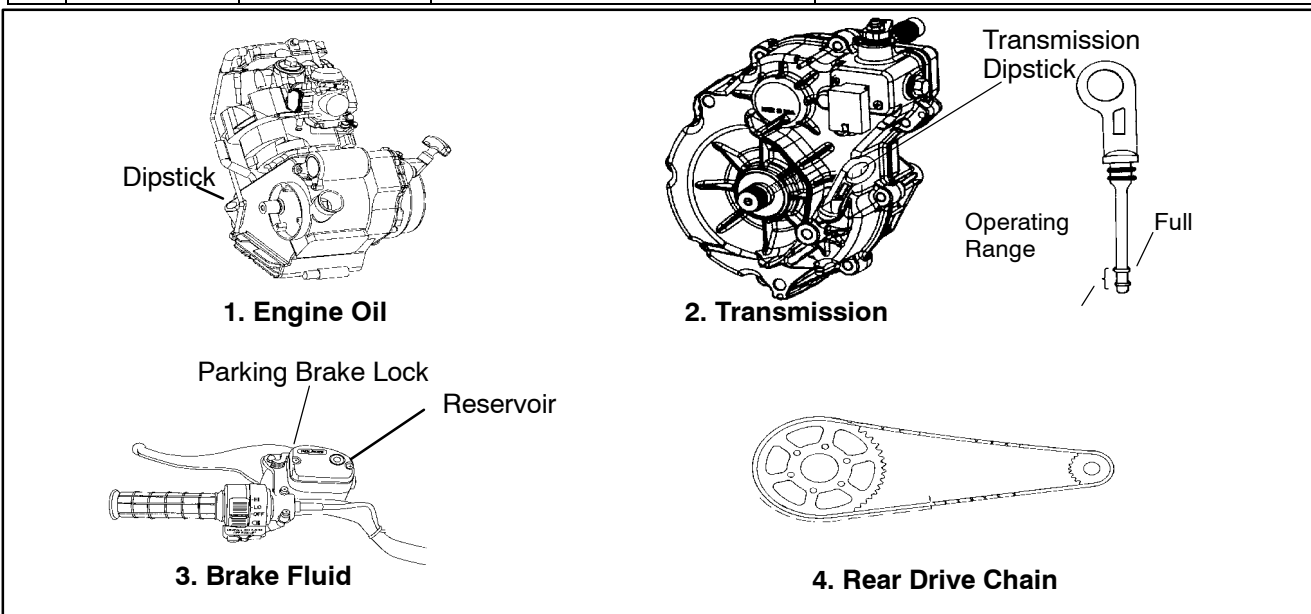

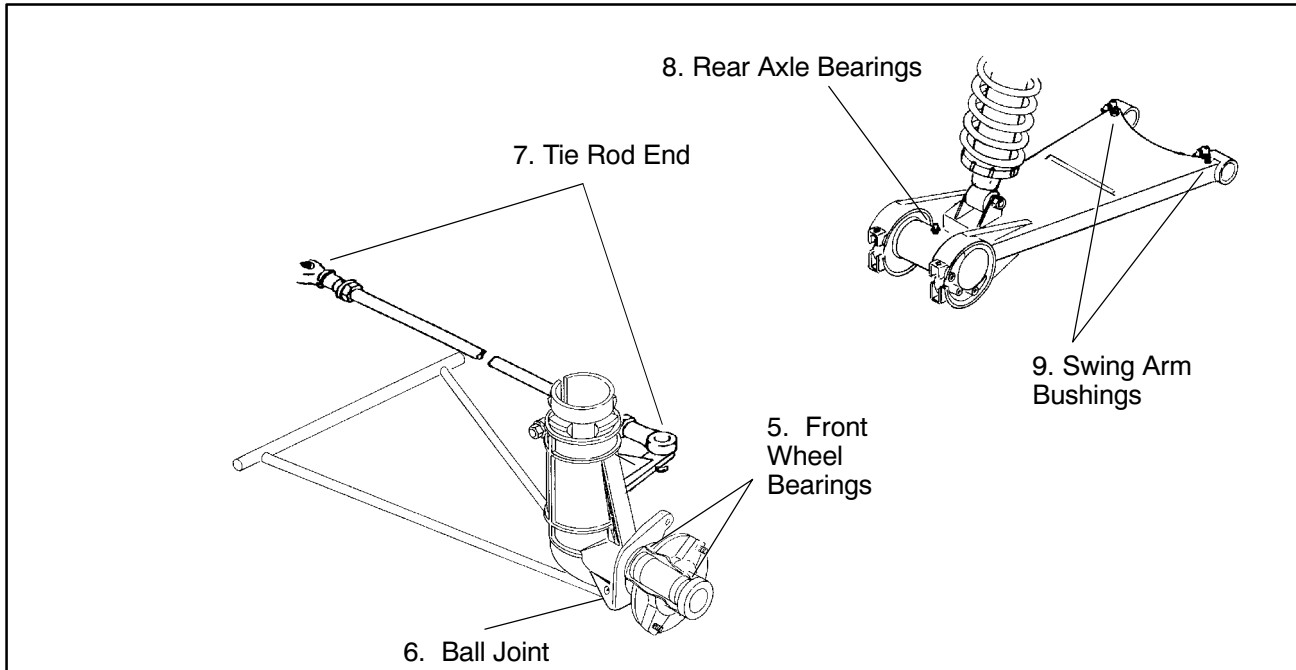
**MAINTENANCE QUICK REFERENCE CONT'D**

III. #	Item	Lube Rec.	Method	Frequency*
5	Front Wheel Bearings	Sealed; Replace	Inspect and replace bearings if necessary	Annually ②
6	Ball Joint	Polaris All Season Grease③	Locate grease fitting on back side of struts and grease with grease gun.	Semi-annually ①
7	Tie Rod Ends	Polaris All Season Grease③	Lift boot. Clean away dirt and grease. Apply fresh grease by hand and reassemble.	Semi-annually ①
8	Rear Axle Bearings	Polaris All Season Grease③	Locate grease fitting on eccentric and grease with grease gun.	Semi-annually ①
9	Swing Arm Bushings	Polaris All Season Grease③	Locate grease fitting on swing arm and grease with grease gun.	Semi-annually ①

\* More often under severe use, such as operated in water or under severe loads.

① Semi-annually or 50 hours of operation (refer to Maintenance Schedule for additional information)

② Annually or 100 hours of operation (refer to Maintenance Schedule for additional information)

③ Grease conforming to NLGI No. 2, such as Polaris Premium All Season Grease, Conoco Superlube M or Mobilegrease Special



**SPECIAL TOOLS**

<b>PART NUMBER</b>	<b>TOOL DESCRIPTION</b>	<b>CHAPTER TOOL USED IN</b>
<b>PA-44689</b>	Valve Clutch Adjuster	2
<b>2870872</b>	Shock Spanner Wrench	2, 5
<b>8712100DX or 8712500</b>	Tachometer	2,10
<b>2200634</b>	Valve Seat Reconditioning Kit	3
<b>2870390</b>	Piston Support Block	3
<b>2870159</b>	Flywheel Puller	3
<b>2871293</b>	Slotted Nut Socket	3
<b>PV-43527</b>	Oil Filter Wrench	3
<b>2872314</b>	Carburetor Float Adjustment Tool	4
<b>2870975</b>	Mity Vac™ Pressure Test Tool	4, 9
<b>2870871</b>	Ball Joint Replacement Tool	5
<b>2870623</b>	Shock Absorber Spring Compression Tool	5
<b>2871572</b>	Strut Rod Wrench	5
<b>2871573</b>	LH Strut Spring Compressor	5
<b>2871574</b>	RH Strut Spring Compressor	5
<b>2870506</b>	Clutch Puller	6
<b>9314177</b>	Clutch Holding Wrench	6
<b>2871358</b>	Clutch Holding Fixture	6
<b>2870341</b>	Drive Clutch Spider Removal and Install Tool	6
<b>2870654</b>	Clutch Offset Alignment Tool	6
<b>2870913</b>	Driven Clutch Puller	6
<b>2870910</b>	Roller Pin Tool	6
<b>2871226</b>	Clutch Bushing Replacement Tool Kit	6
<b>2870386</b>	Piston Pin Puller	6
<b>8700220</b>	Clutch Compression Tool	6
<b>2871710</b>	10" Center Distance Tool	8
<b>PV-43568</b>	Fluke™ 77 Digital Multimeter	10
<b>2870630</b>	Timing Light	10
<b>2870836</b>	Battery Hydrometer	10
<b>8712100 or 8712500</b>	Tachometer	10

**NOTE:** Polaris dealers can order the tools listed above through the SPX Service Tools catalog.





## TRANSMISSION LUBRICATION

The transmission lubricant level should be checked and changed in accordance with the maintenance schedule.

- Be sure vehicle is level before proceeding.
- Check vent hose to be sure it is routed properly and unobstructed.
- Follow instructions on following pages to check / change transmission lubricant.

### TRANSMISSION SPECIFICATIONS

*Specified Lubricant:*  
Polaris Premium Synthetic Gearcase Lubricant (PN 2871477) (Gallon) (PN 2871478) (12 oz.)

*Capacity:* 11.3 oz. (335 ml)

*Drain Plug / Fill Plug Torque:*

14 ft. lbs. (19.4 Nm)

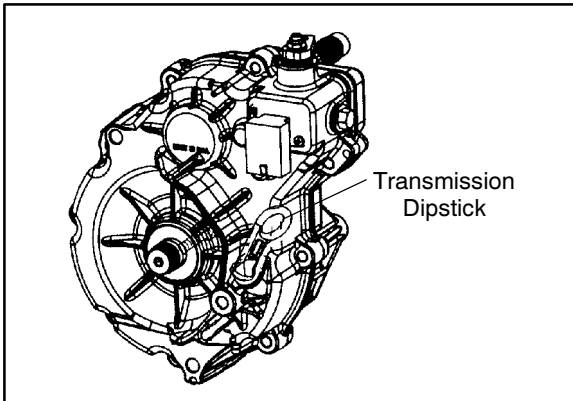

### To check the level:

1. Remove dipstick and wipe clean.
2. Reinstall dipstick completely, remove and check the level. Add the proper lubricant as required to bring level into operating range as shown.

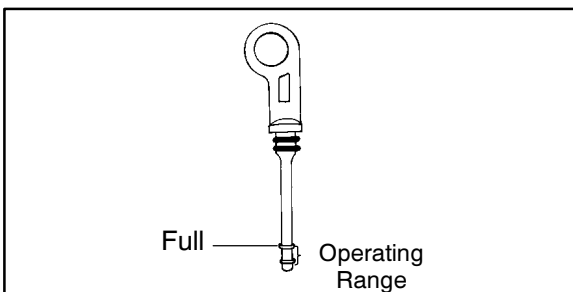

## TRANSMISSION FLUID CHANGE/TORQUE STOP ADJUSTMENT

1. Remove skid plate (if necessary).
2. Place a drain pan beneath the transmission oil drain plug area.
3. Loosen jam nut (A).
4. Turn adjuster bolt (B) in to allow the removal of drain plug.
5. Remove the drain plug and wipe the magnetic end clean to remove accumulated metallic filings.
6. After the oil has drained completely, install a new sealing washer and install the drain plug. Torque to 14 ft. lbs. (19.3 Nm).
7. Turn adjuster bolt (B) out until it touches the frame, and then an additional 1/2 turn.

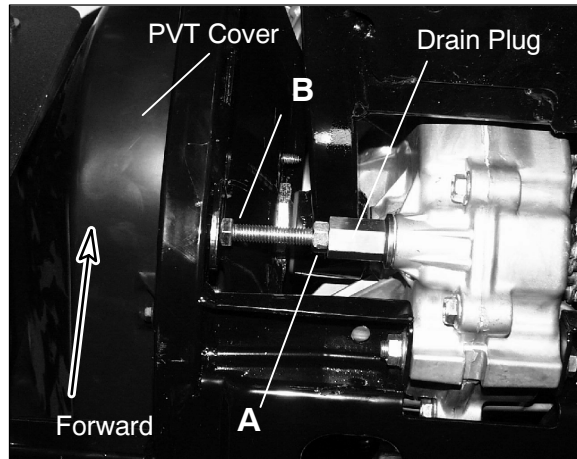

8. Tighten the jam nut securely while holding the adjuster bolt.
9. Add the proper lubricant through the dipstick hole until the oil level is between the upper and lower limits. Do not overfill.
10. Check for leaks.
11. Reinstall skid plate if removed in Step 1.



## TRANSMISSION GEARSHIFT LINKAGE ADJUSTMENT/ INSPECTION

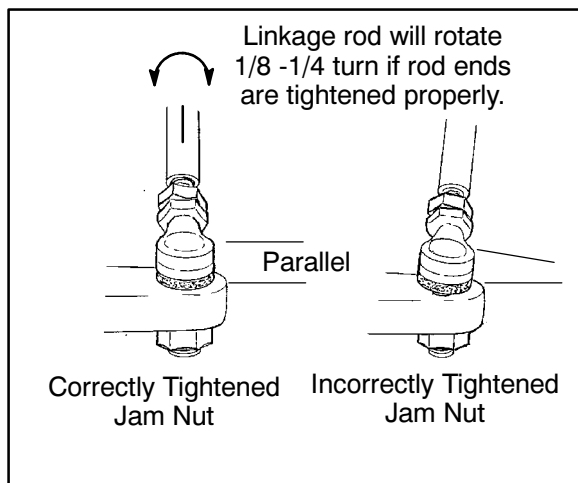

- If shifting problems are encountered, the transmission linkage may require adjustment.
- Visually check for contact of shift lever to shifter opening in the front fender. Ensure shift linkage or shift lever is not contacting the frame or exhaust components.
- Tighten shift linkage rod end jam nuts properly after adjustment. You should be able to rotate the linkage rod between 1/8 and 1/4 turn after both jam nuts are tight.
- The transmission shift linkage should be periodically inspected for wear and parts replaced as required to remove excess play from shift linkage.
- Refer to Transmission chapter for more information.

**NOTE:** The rod end must be held when tightening the jam nut to prevent damage to the rod end.

## SHIFT LINKAGE ADJUSTMENT

1. Inspect shift linkage tie rod ends, clevis and pivot bushings and replace if worn or damaged.
2. Place gear selector in neutral.
3. Loosen rod end adjuster jam nuts (A) on both ends of linkage rod. **NOTE:** The jam nut closest to the knurled end is Left Hand thread.

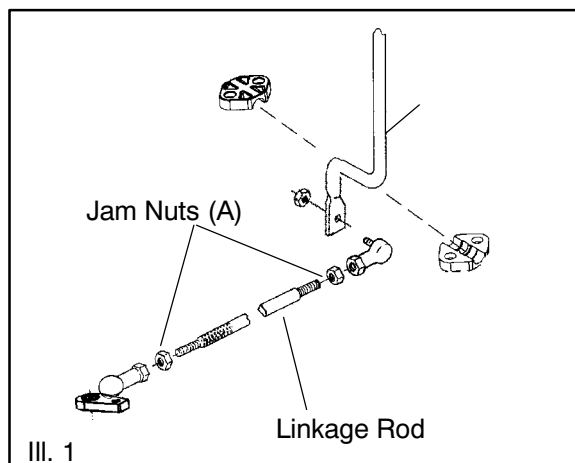

4. Turn linkage rod (A) to shorten or lengthen rod until the shift lever is centered on hole in the fender.

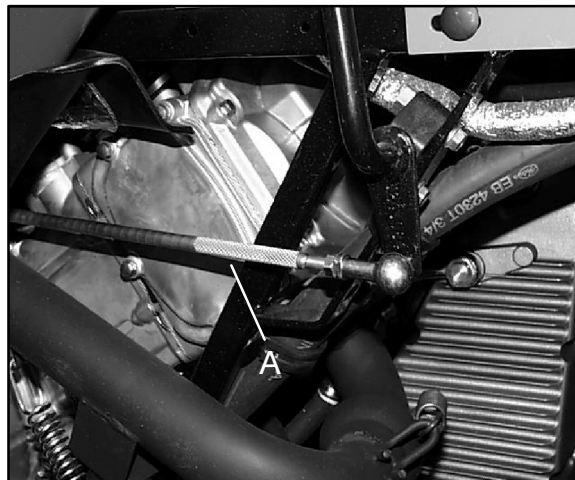

5. Hold rod end parallel to mounting surface and tighten jam nuts securely.



## THROTTLE OPERATION - ALL MODELS

Check for smooth throttle opening and closing in all handlebar positions. Throttle lever operation should be smooth and lever must return freely without binding.

1. Place the gear selector in neutral.
2. Set parking brake.
3. Start the engine and let it idle.
4. Turn handlebars from full right to full left. If idle speed increases at any point in the turning range, inspect throttle cable routing and condition. If cable is routed properly and in good condition, repeat adjustment procedure.
5. Replace the throttle cable if worn, kinked, or damaged.

## CHOKE (ENRICHER) ADJUSTMENT

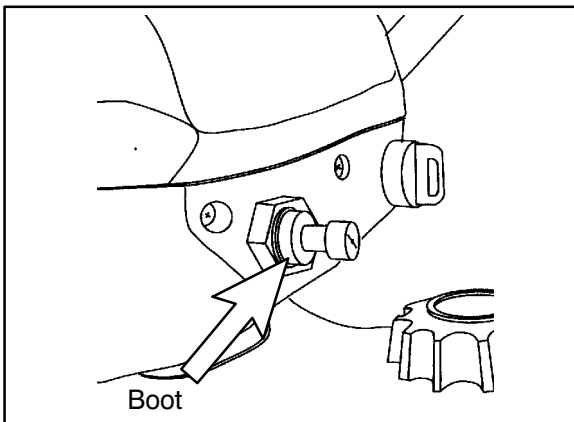

If the choke knob does not stay out when pulled, adjust the choke tension by tightening the tensioner located under the rubber boot between the choke knob and nut. Firmly grasp the rubber boot and tighten until the choke slides freely but stays out when pulled.

Verify free play of 1/16–3/16" (1.6–4.76 mm) and smooth operation of choke cable.

If smooth choke operation is not obtainable, inspect choke cable for kinks or sharp bends in routing.

## PILOT SCREW (IDLE MIXTURE) ADJUSTMENT

**NOTE:** These procedures are intended as reference only. Actual final settings may be different depending on the atmospheric conditions in your area.

1. Turn pilot screw in (clockwise) until *lightly* seated. Turn screw out the specified number of turns. **NOTE:** Do not tighten the pilot screw forcefully against the seat or the screw and/or seat will be permanently damaged.

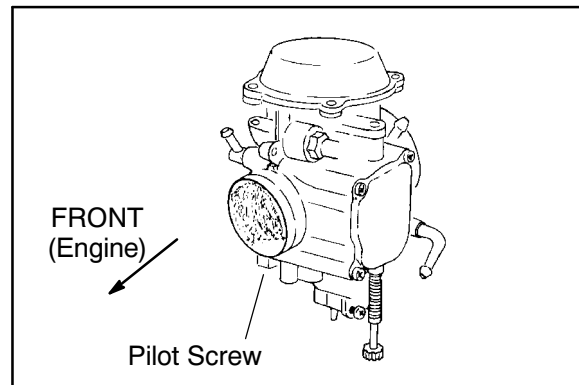

**Pilot Screw Adjustment:**

**2.0 Turns**

2. Connect an accurate tachometer that will read in increments of + or - 50 RPM such as the PET 2100DX (PN 8712100DX) or the PET 2500 (PN 8712500).
3. Start engine and warm it up to operating temperature (about 10 minutes).
4. Set idle speed to 1300 RPM. Always check throttle cable freeplay after adjusting idle speed and adjust if necessary.
5. Slowly turn mixture screw clockwise using the pilot screw wrench until engine begins to miss.
6. Slowly turn mixture screw counterclockwise until idle speed increases to maximum RPM. Continue turning counterclockwise until idle RPM begins to drop.
7. Center the pilot screw between the points in Step 5 and 6.
8. Re adjust idle speed if not within specification.



## **IDLE SPEED ADJUSTMENT**

1. Start engine and warm it up thoroughly.

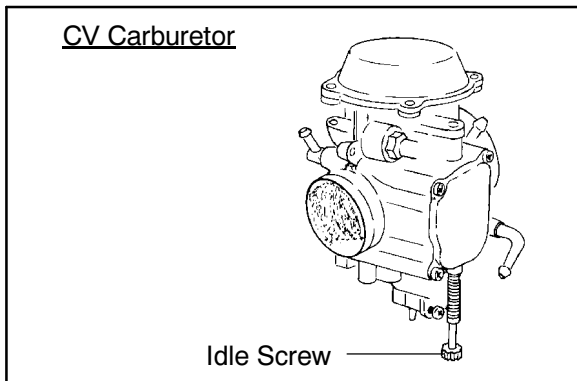

**Idle Speed:**  
**1300 ± 100 RPM**

2. Adjust idle speed by turning the idle adjustment screw in (clockwise) to increase or out (counterclockwise) to decrease RPM. (Refer to Ill. at right).

**NOTE:** Adjusting the idle speed affects throttle cable freeplay and electronic throttle control (ETC) adjustment. Always check throttle cable freeplay after adjusting idle speed and adjust if necessary.

## **ELECTRONIC THROTTLE CONTROL (ETC SWITCH)/ THROTTLE CABLE ADJUSTMENT**

1. Slide the boots off inline cable adjuster sleeve. Loosen adjuster locknut.
2. With handlebars centered and wheels pointing forward, turn adjuster sleeve until 1/16" - 1/8" freeplay is achieved at the thumb lever. After making any adjustment, "flip" the lever slightly to confirm adjustment.

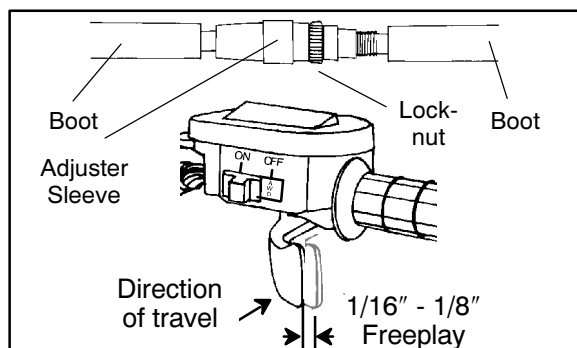

3. Tighten locknut and slide boots over cable adjuster until they touch at the middle point of the adjuster.
4. With engine running, turn the handlebars from full left to full right with transmission in neutral. Engine RPM should not change and the engine should not die. If either of these occur, return to the first step.

## **THROTTLE OPERATION**

**To remove the ETC cover:**

1. Use a medium flat blade screwdriver and insert blade into the pockets of the cover starting on the #1 position.

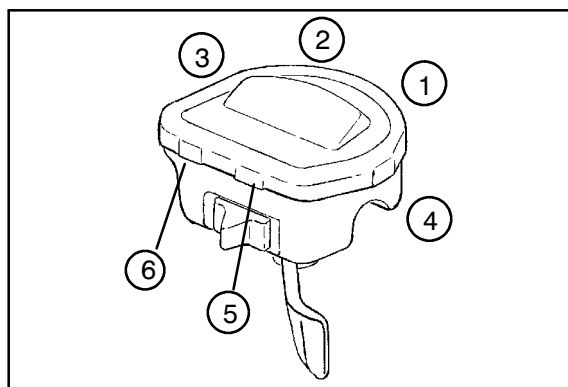

2. Twist screwdriver slightly while lifting on the cover to release snap.
3. Repeat procedure at the other five locations as shown. **NOTE:** Do not attempt to remove cover until all latch points are released.

Check for smooth throttle opening and closing in all handlebar positions. Throttle lever operation should be smooth and lever must return freely without binding. Replace the throttle cable if worn, kinked, or damaged.

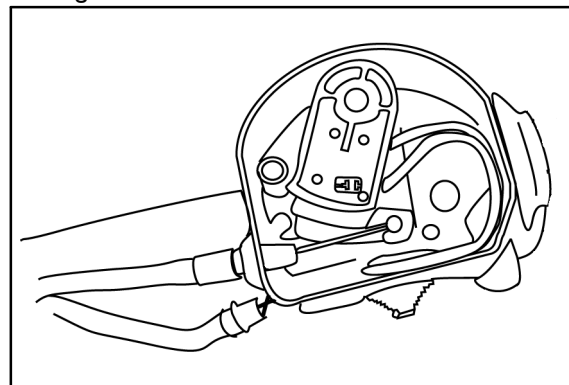

**NOTE:** When replacing the cover, check for correct placement of cover O-ring.



## FUEL SYSTEM

### ⚠ WARNING

*Gasoline is extremely flammable and explosive under certain conditions.*

- Always stop the engine and refuel outdoors or in a well ventilated area.
- Do not smoke or allow open flames or sparks in or near the area where refueling is performed or where gasoline is stored.
- Do not overfill the tank. Do not fill the tank neck.
- If you get gasoline in your eyes or if you swallow gasoline, seek medical attention immediately.
- If you spill gasoline on your skin or clothing, immediately wash it off with soap and water and change clothing.
- Never start the engine or let it run in an enclosed area. Engine exhaust fumes are poisonous and can result loss of consciousness or death in a short time.
- Never drain the float bowl when the engine is hot. Severe burns may result.

## FUEL LINES

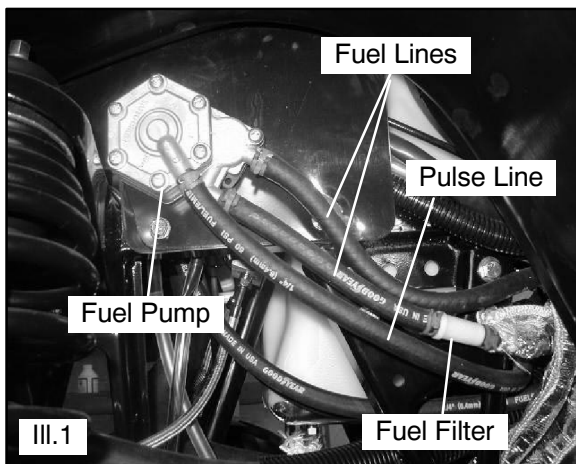

1. Check fuel lines for signs of wear, deterioration, damage or leakage. Replace if necessary.
2. Be sure fuel lines are routed properly and secured with cable ties. **CAUTION:** Make sure lines are not kinked or pinched.
3. Replace all fuel lines every two years.

## VENT LINES

1. Check fuel tank, oil tank, carburetor, battery and transmission vent lines for signs of wear, deterioration, damage or leakage. Replace every two years.
2. Be sure vent lines are routed properly and secured with cable ties. **CAUTION:** Make sure lines are not kinked or pinched.

## FUEL FILTER

The fuel filter should be replaced in accordance with the Periodic Maintenance Chart.

1. Shut off fuel supply at fuel valve.
2. Remove line clamps at both ends of the filter.
3. Remove fuel lines from filter.
4. Install new filter and clamps onto fuel lines with arrow pointed in direction of fuel flow.

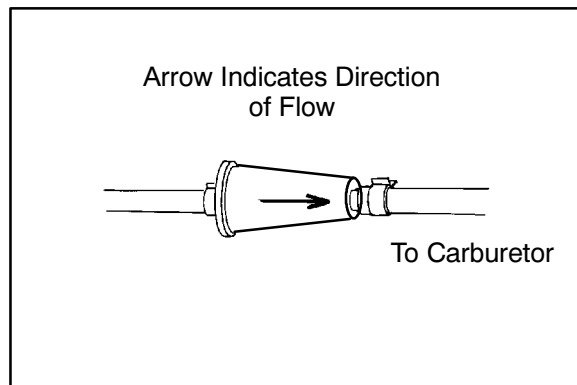

5. Install clamps on fuel line.
6. Turn fuel valve ON.
7. Start engine and inspect for leaks.

## CARBURETOR DRAINING

The carburetor float bowl should be drained periodically to remove moisture or sediment from the bowl, or before extended periods of storage.

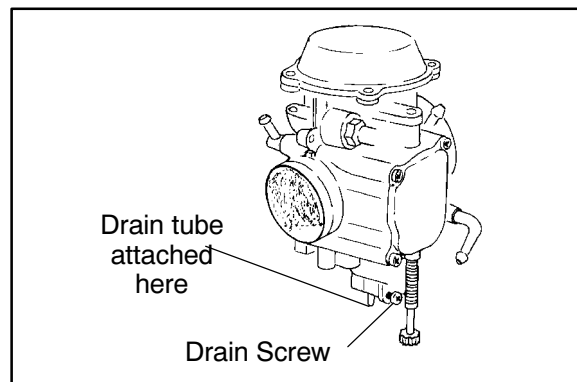



**NOTE:** The bowl drain screw is located on the bottom left side of the float bowl.

1. Turn fuel valve to the off position.
2. Place a clean container beneath the bowl drain spigot or bowl drain hose.

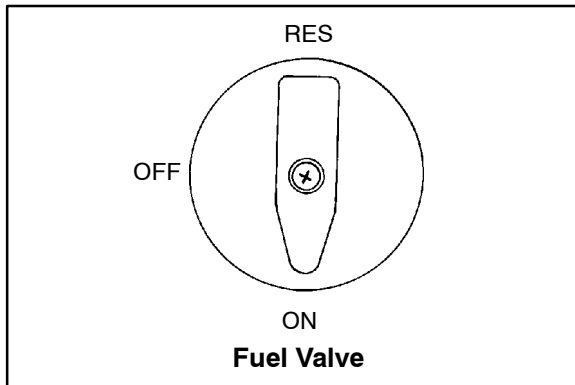

3. Turn drain screw out two turns and allow fuel in the float bowl and fuel line to drain completely.
4. Inspect the drained fuel for water or sediment.
5. Tighten drain screw.
6. Turn fuel valve to "ON".
7. Start machine and check for leaks.

**NOTE:** If there is a tube attached, it must be reattached as this will effect engine performance.

## COMPRESSION TEST

**NOTE:** This Polaris 4-Stroke engine is equipped with an automatic decompressor. Compression readings will vary in proportion to cranking speed during the test. Average compression (measured) is about **70-90 psi** during a compression test.

Smooth idle generally indicates good compression. Low engine compression is rarely a factor in running condition problems above idle speed. Abnormally high compression can be caused by a decompressor malfunction, or worn or damaged exhaust cam lobes. Inspect camshaft and automatic decompression mechanism if compression is abnormally high.

A cylinder leakage test is the best indication of engine condition on models with automatic decompression. Follow tester manufacturer's instructions to perform a cylinder leakage test. (Never use high pressure leakage testers as crankshaft seals may dislodge and leak).

### Cylinder Compression

Standard 70-90 PSI

### Cylinder Leakage

Service Limit: 10 %  
(Inspect for cause if leakage exceeds 10%)

## ENGINE MOUNTS

Inspect rubber engine mounts for cracks or damage.

## ENGINE FASTENER TORQUE

Check engine fasteners and ensure they are tight.

## BATTERY MAINTENANCE

### **WARNING**

Battery electrolyte is poisonous. It contains sulfuric acid. Serious burns can result from contact with skin, eyes or clothing. Antidote:

**External:** Flush with water.

**Internal:** Drink large quantities of water or milk. Follow with milk of magnesia, beaten egg, or vegetable oil. Call physician immediately.

**Eyes:** Flush with water for 15 minutes and get prompt medical attention.

Batteries produce explosive gases. Keep sparks, flame, cigarettes, etc. away. Ventilate when charging or using in an enclosed space. Always shield eyes when working near batteries. **KEEP OUT OF REACH OF CHILDREN.**

**NOTE:** All 2003 Trail Boss ATV batteries are Maintenance-Free design and construction. All Maintenance-Free batteries are fully charged and tested at the factory before installation. Expected shelf life is 6-8 months depending on storage conditions. As a general rule before placing the battery into service, check the battery condition and charge accordingly.



**Maintenance-Free batteries** are permanently sealed at the time of manufacture. The use of lead-calcium and AGM technology instead of lead-antimony allows the battery acid to be fully absorbed. For this reason, a Maintenance-Free battery case is dark and the cell caps are not removable, since there is no need to check electrolyte level.

**NEVER attempt to add electrolyte or water to a Maintenance-Free battery. Doing so will damage the case and shorten the life of the battery. Refer to the Battery Maintenance Video (PN 9917987) for proper instruction on servicing Maintenance-Free batteries.**

The battery is located under the left rear fender.

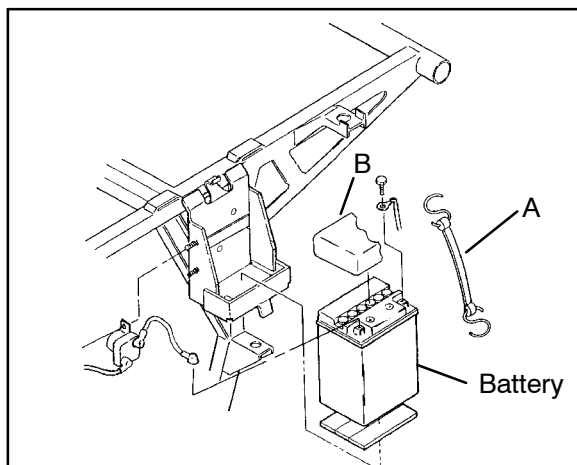

### To remove the battery:

1. Disconnect holder strap (A) and remove cover (B).
2. Disconnect battery negative (-) (black) cable first, followed by the positive (+) (red) cable.



### CAUTION

**To reduce the chance of sparks: Whenever removing the battery, disconnect the negative (black) cable first. When reinstalling the battery, install the negative cable last.**

3. Remove the battery.
4. Clean battery cables and terminals with a stiff wire brush. Corrosion can be removed using a solution of one cup water and one tablespoon baking soda. Rinse well with clean water and dry thoroughly.
5. Reinstall battery, attaching positive (+) (red) cable first and then the negative (-) (black) cable.
6. Coat terminals and bolt threads with Dielectric Grease (PN 2871329).
7. Reinstall battery cover and holder strap.

## SPARK PLUG

1. Remove spark plug high tension lead. Clean plug area so no dirt and debris can fall into engine when plug is removed.
2. Remove spark plug.
3. Inspect electrodes for wear and carbon buildup. Look for a sharp outer edge with no rounding or erosion of the electrodes.
4. Clean with electrical contact cleaner or a glass bead spark plug cleaner only. **CAUTION:** A wire brush or coated abrasive should not be used.
5. Measure gap with a wire gauge. Refer to specifications for proper spark plug type and gap. Adjust gap if necessary by bending the side electrode carefully.

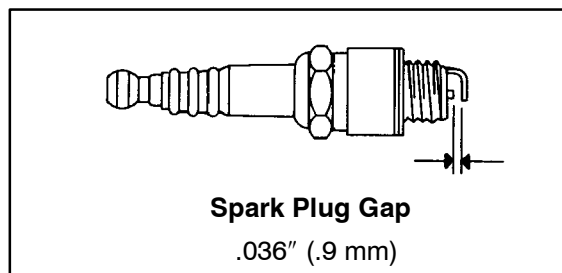

6. If necessary, replace spark plug with proper type. **CAUTION:** Severe engine damage may occur if the incorrect spark plug is used.
7. Apply a small amount of anti-seize compound to the spark plug threads.
8. Install spark plug and torque to 14 ft. lbs.

### Recommended Spark Plug:

**NGK BKR6E**

**Spark Plug Torque: 14 Ft. Lbs. (19 Nm)**

## IGNITION TIMING

Refer to Electrical chapter for ignition timing procedure.

### Ignition Timing:

**30°±2° BTDC@5000RPM**





## ENGINE-TO-FRAME GROUND

Inspect engine-to-frame ground cable connection. Be sure it is clean and tight.

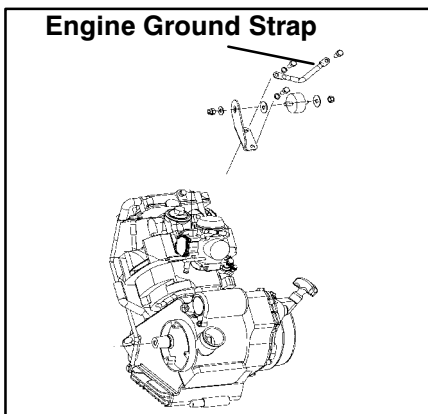

## MAIN AIR FILTER CLEANING

It is advisable to replace the filter when it is dirty. However, in an emergency it is permissible to clean the main filter if you observe the following practices.

- **Never** immerse the filter in water since dirt can be transferred to the clean air side of the filter.
- If compressed air is used **never** exceed a pressure of 40 PSI. Always use a dispersion type nozzle to prevent filter damage and clean from the inside to the outside.
- Replace the air filter every 50 hours, and possibly more often in very dirty conditions.

## AIR FILTER/PRE-FILTER SERVICE

It is recommended that the air filter and pre filter be replaced annually. When riding in extremely dusty conditions, replacement is required more often.

The pre filter should be cleaned before each ride using the following procedure:

1. Lift up on the rear of the seat.
2. Pull the seat back and free of the tabs. **NOTE:** When reinstalling seat, make sure the slots in the seat engage the tabs in the fuel tank.
3. Remove clips from air box cover (A) and remove cover. Inspect the gasket (E). It should adhere tightly to the cover and seal all the way around.
4. Loosen clamp and remove air filter assembly (B & C).

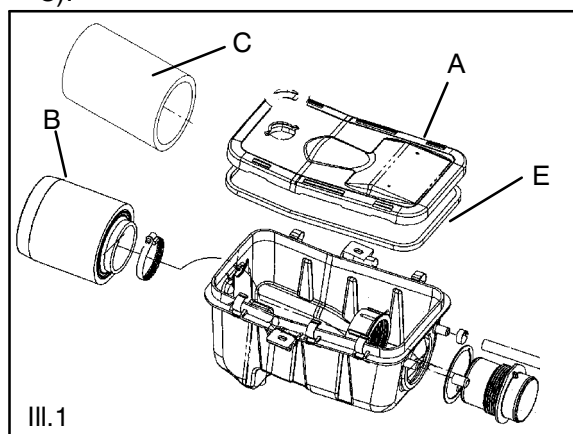

### Cleaning:

5. Slip the pre-filter element (C) off of main element. Clean the pre filter with high flash point solvent, followed by hot soapy water.
6. Rinse and dry thoroughly.
7. Inspect element for tears or damage.
8. Apply foam filter oil or clean engine oil and squeeze until excess oil is removed.
9. Inspect main filter and replace if necessary. If the filter has been soaked with fuel or oil it must be replaced.

### Installation:

10. Reinstall pre-filter element over main filter. Be sure the element covers entire surface of main filter without folds, creases, or gaps.
11. Reinstall filter on main filter mount. Place filter clamp over the assembly and tighten.





**NOTE:** Apply a small amount of general purpose grease to the sealing edges of the filter before reinstalling.

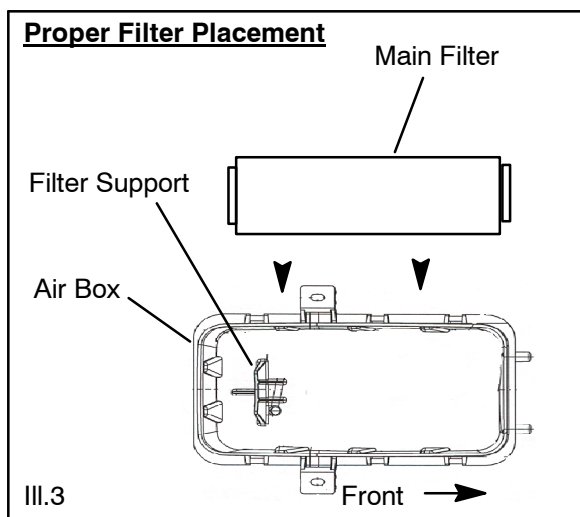
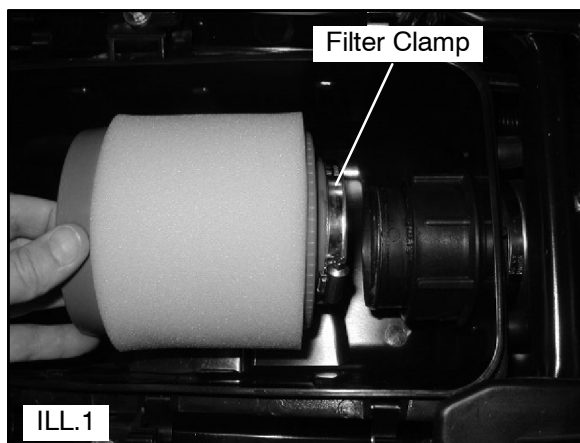

**NOTE:** The air filter should rest on the filter support. Proper placement of the air filter is important to prevent rattles and air leaks. See Illustration above.

1. Install air box cover and secure with clips.

## AIR BOX SEDIMENT TUBE

Periodically check the air box drain tube located toward the rear of the machine. Drain whenever deposits are visible in the clear tube.

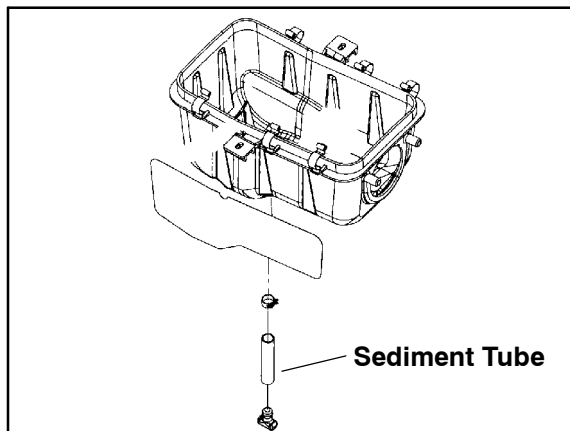

**NOTE:** The sediment tube will require more frequent service if the vehicle is operated in wet conditions or at high throttle openings for extended periods.

1. Remove drain plug from end of sediment tube.
2. Drain tube.
3. Reinstall drain plug.

## RECOIL HOUSING

- Drain the housing periodically to remove moisture.

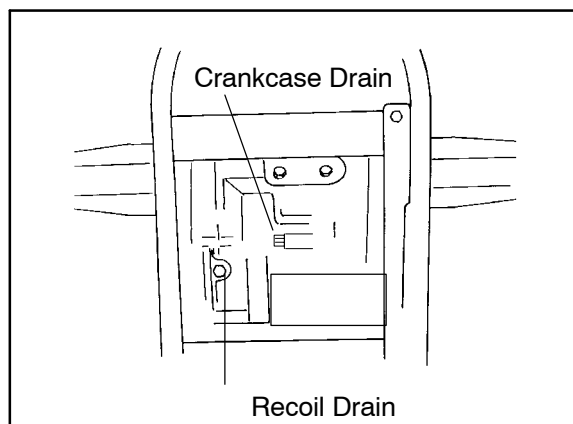

- Drain the recoil housing after operating the ATV in very wet conditions. This should also be done before storing the ATV. The drain screw is located at the bottom of the recoil housing. Remove the screw with a 10mm wrench. Reinstall screw once housing has been drained.
- **CAUTION:** Make sure the manual start handle is fully seated on the recoil housing, especially when travelling in wet areas. If it is not sealed properly, water may enter the recoil housing and damage components.



sealed properly, water may enter the recoil housing and damage components.

- Water will enter the recoil housing if the starter handle is disengaged from the rope guide when under water.
- After travelling in wet areas, the recoil housing and starter should always be drained completely by removing the recoil.
- Do not open the crankcase drain unless the engine has ingested water. Some engine oil will be lost if crankcase drain is opened.
- If recoil handle seal has been damaged, the handle assembly should be replaced.

## PVT DRAIN PLUG & DRYING

**NOTE:** If operating the ATV in or through water, be sure to check the PVT cover and other components for water ingestion. The ATV should be checked immediately.

1. To release any water that maybe trapped in the PVT cover, simply remove the PVT drain plug and O-ring located on the bottom of the PVT cover and let the water drain out. The PVT drain plug is shown below.

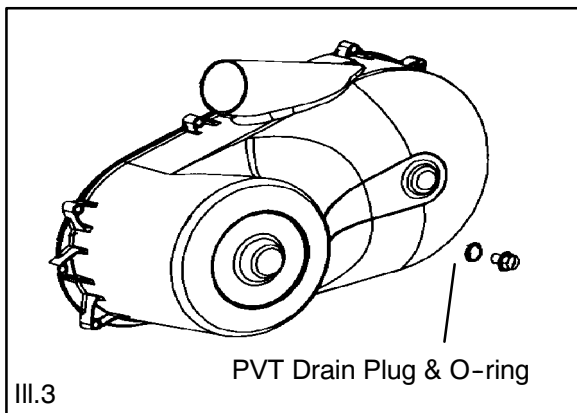

2. To further expel water from the cover and to dry out the PVT system, shift the transmission to neutral and rev engine slightly to expel the moisture and air-dry the belt and clutches. Allow engine RPM to settle to idle speed, shift transmission to lowest available range and test for belt slippage. Operate ATV in lowest available range for a short period of time until PVT system is dry.

## ENGINE OIL LEVEL

**To check the oil level:**

1. Set machine on a level surface.
2. Start and run engine for 20-30 seconds. This will return oil to its true level in the engine sump.
3. Stop engine, remove dipstick and wipe dry with a clean cloth.
4. Reinstall dipstick, screwing into place.
5. The dipstick must be screwed completely in to ensure accurate measurement.
6. Remove dipstick and check to see that the oil level is in the normal range. The oil should be between the top of the bottom crosshatched area and the bottom of the top crosshatched area. Add oil as indicated by the level on the dipstick. Do not overfill.

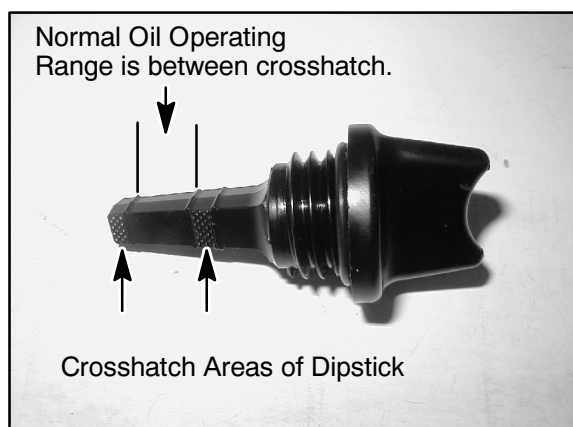

**NOTE:** Do not fill the over the normal oil operating range. Filling over the normal operating range could cause a mist of oil to enter the air box.

**NOTE:** Rising oil level between checks in cool weather driving, can indicate moisture collecting in the oil reservoir. If the oil level is over the full mark, change the oil.

### **Recommended Engine Oil:**

**Polaris Premium 4 All Season Synthetic, 0W-40 (PN 2871281)**

**Ambient Temperature Range:  
-40° F to 120° F**



## OIL AND FILTER CHANGE

1. Place vehicle on a level surface.
2. Clean area around drain plug at bottom of oil pan.
3. Run engine two to three minutes until warm. Stop engine.
4. Place a drain pan beneath oil pan and remove drain plug from under the crankcase. **CAUTION:** Oil may be hot. Do not allow hot oil to come into contact with skin as serious burns may result.
5. Allow oil to drain completely.

**NOTE:** It is not necessary to drain the oil from the oil cooler, unless contaminants, water, or debris are found in the crankcase oil.

6. Replace sealing washer (A) on drain plug. **NOTE:** The sealing surfaces on drain plug and oil tank should be clean and free of burrs, nicks or scratches.
7. Reinstall drain plug and torque to 14 ft. lbs. (19 Nm).

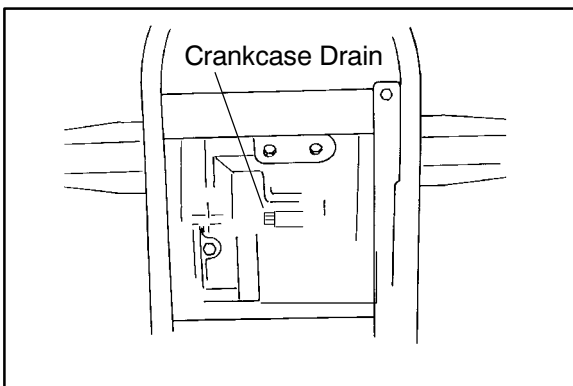
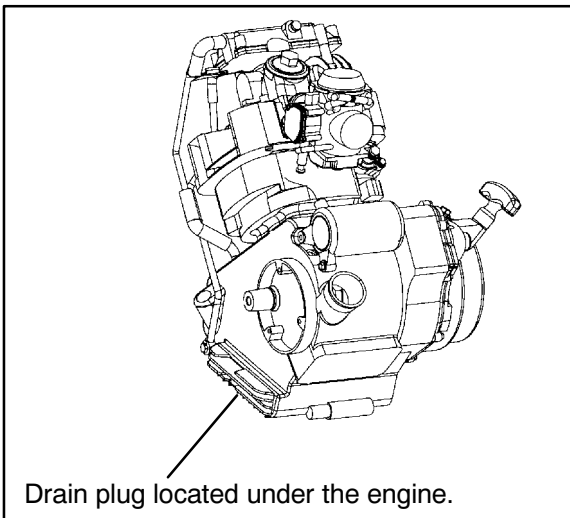

Engine Sump Drain Plug - Bottom View

8. The oil filter is located on the right side of the machine. Place shop towels beneath oil filter. Using an oil filter wrench, turn filter counterclockwise to remove.

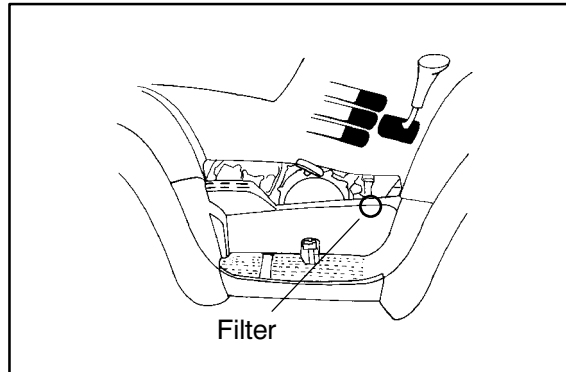

9. Using a clean dry cloth, clean filter sealing surface on crankcase.
10. Lubricate O-ring on new filter with a film of engine oil. Check to make sure the O-ring is in good condition.
11. Install new filter and turn by hand until filter gasket contacts the sealing surface, then turn and additional 1/2 turn.

**NOTE:** The sealing surfaces on the drain plug and crankcase should be clean and free of burrs, nicks or scratches.

12. Remove dipstick and fill tank with 2 quarts (1.9 l) of Polaris Premium 4 Synthetic Oil (PN 2871281).
13. Place gear selector in neutral and set parking brake.
14. Start the engine and let it idle for one to two minutes. Stop the engine and inspect for leaks.
15. Re-check the oil level on the dipstick and add oil as necessary to bring the level to the upper mark on the dipstick.
16. Dispose of used filter and oil properly.

**Crankcase Drain Plug Torque:**  
14 ft. lbs. (19 Nm)

**Oil Filter Torque:**  
Turn by hand until filter gasket contacts sealing surface, then turn an additional 1/2 turn

**Oil Filter Wrench:**  
(PV-43527)



## VALVE CLEARANCE

Inspect and adjust valve clearance while the engine is cold and the piston positioned at Top Dead Center (TDC) on compression stroke.

1. Remove the seat.
2. Remove body panels and fuel tank as necessary to gain access to valve cover.
3. Remove the spark plug high tension lead and remove the spark plug. **CAUTION:** Place a clean shop towel into the spark plug cavity to prevent dirt from entering.
4. Remove plastic valve plugs.

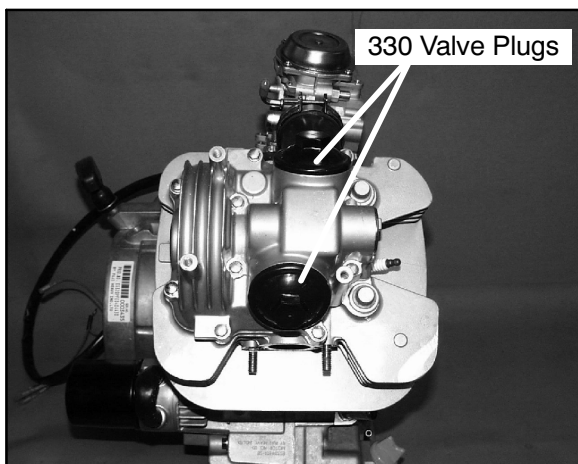

5. Remove timing inspection plug from recoil housing.

**CAUTION:** Failure to position the crankshaft at TDC on compression stroke will result in improper valve adjustment.

6. Rotate engine slowly with recoil rope, watching the intake valve(s) open and close.

**NOTE:** Observe the intake valve closing and then start to open, continue to rotate until the “T” aligns with pointer. The camshaft lobes should be pointing downward.

7. Verify accurate TDC positioning by observing the “T” mark aligned with the pointer in the timing inspection hole. In this position there should be clearance on all valves.

**INTAKE VALVE CLEARANCE:**  
 $0.006 \pm 0.0008''$  ( $0.15 \pm 0.02$  mm)  
 BTDC on compression

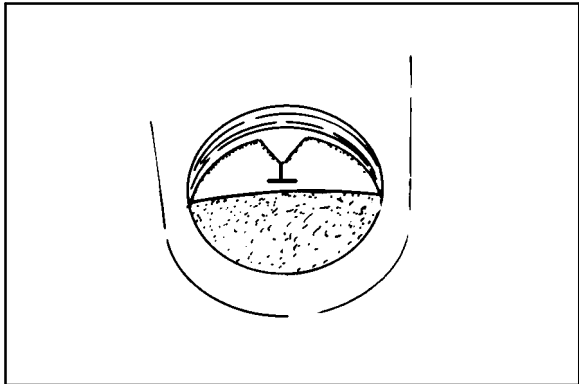

## INTAKE VALVE CLEARANCE ADJUSTMENT

1. Insert a .006" (.15mm) feeler gauge between end of intake valve stem and clearance adjuster screw.
2. Using Valve/Clutch Adjuster (**PA-44689**), loosen adjuster lock nut and turn adjusting knob until there is a slight drag on the feeler gauge.

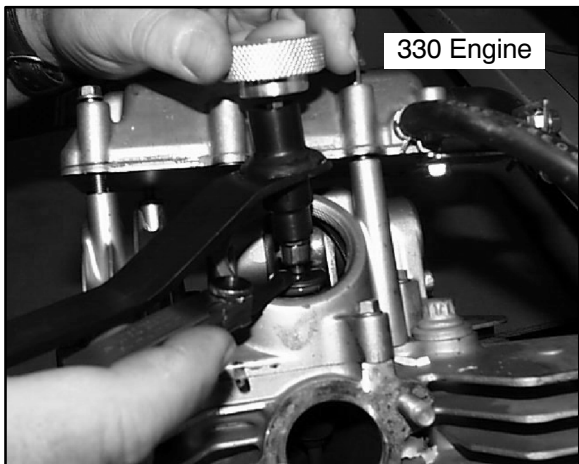

3. Hold adjuster screw and tighten adjuster lock nut securely.
4. Re-check the valve clearance.
5. Repeat adjustment procedure if necessary until clearance is correct with locknut secured.

## EXHAUST VALVE CLEARANCE ADJUSTMENT

**NOTE:** The exhaust valve is adjusted the same as the intake valve.



1. Insert .006" feeler gauge between end of exhaust valve stem and adjuster screw.

### EXHAUST VALVE CLEARANCE:

**0.006±0.0008" (0.15±0.02 mm)  
BTDC on compression**

2. Loosen locknut and turn adjuster screw until there is a slight drag on feeler gauge.
3. When clearance is correct, hold adjuster screw and tighten locknut securely
4. Re-check the valve clearance.
5. Repeat adjustment procedure if necessary until clearance is correct with locknut secured.
6. Inspect o-rings on the plastic valve plugs, replace if damaged. Securely fasten valve plugs.
7. Reinstall fuel tank and any body panels that were removed to gain access.

## STEERING

The steering components should be checked periodically for loose fasteners, worn tie rod ends, and damage. Also check to make sure all cotter pins are in place. If cotter pins are removed, they must not be re-used. Always use new cotter pins.

Replace any worn or damaged steering components. Steering should move freely through entire range of travel without binding. Check routing of all cables, hoses, and wiring to be sure the steering mechanism is not restricted or limited. **NOTE:** Whenever steering components are replaced, check front end alignment. Use only genuine Polaris parts.

### ▲ WARNING

**NOTE:** Due to the critical nature of the procedures outlined in this chapter, Polaris recommends steering component repair and adjustment be performed by an authorized Polaris Dealer. Only a qualified technician should replace worn or damaged steering parts. Use only genuine Polaris replacement parts.

One of two methods can be used to measure toe alignment: The string method and the chalk method. If adjustment is required, refer to following pages for procedure.

## TIE ROD END / STEERING INSPECTION

To check for play in the tie rod end, grasp the steering tie rod, pull in all directions feeling for movement.

- Repeat inspection for inner tie rod end (on steering post).
- Replace any worn steering components. Steering should move freely through entire range of travel without binding.

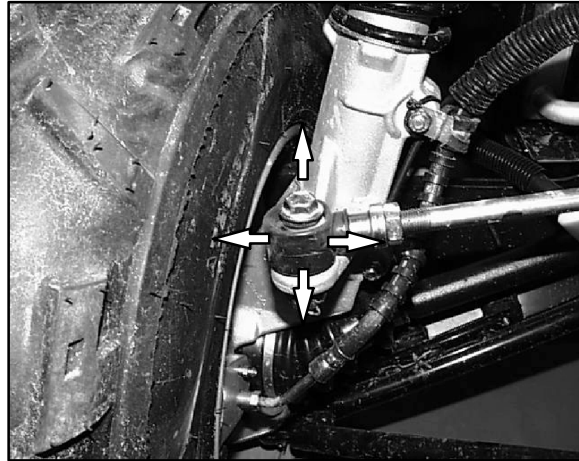

- Elevate front end of machine so front wheels are off the ground. Check for any looseness in front hub / wheel assembly by grasping the tire firmly at top and bottom first, and then at front and rear. Try to move the wheel and hub by pushing inward and pulling outward.

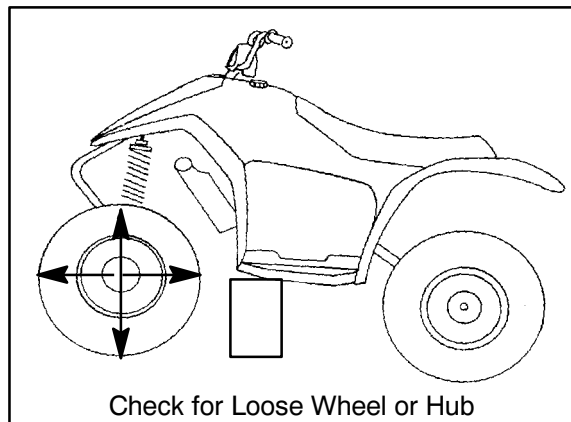



- If abnormal movement is detected, inspect the hub and wheel assembly to determine the cause.
- Refer to the Body/Steering or Final Drive chapter for more information.

## **CAMBER AND CASTER**

The camber and caster are non-adjustable.

## **WHEEL ALIGNMENT METHOD: STRAIGHTEDGE OR STRING**

Be sure to keep handlebars centered. See notes below.

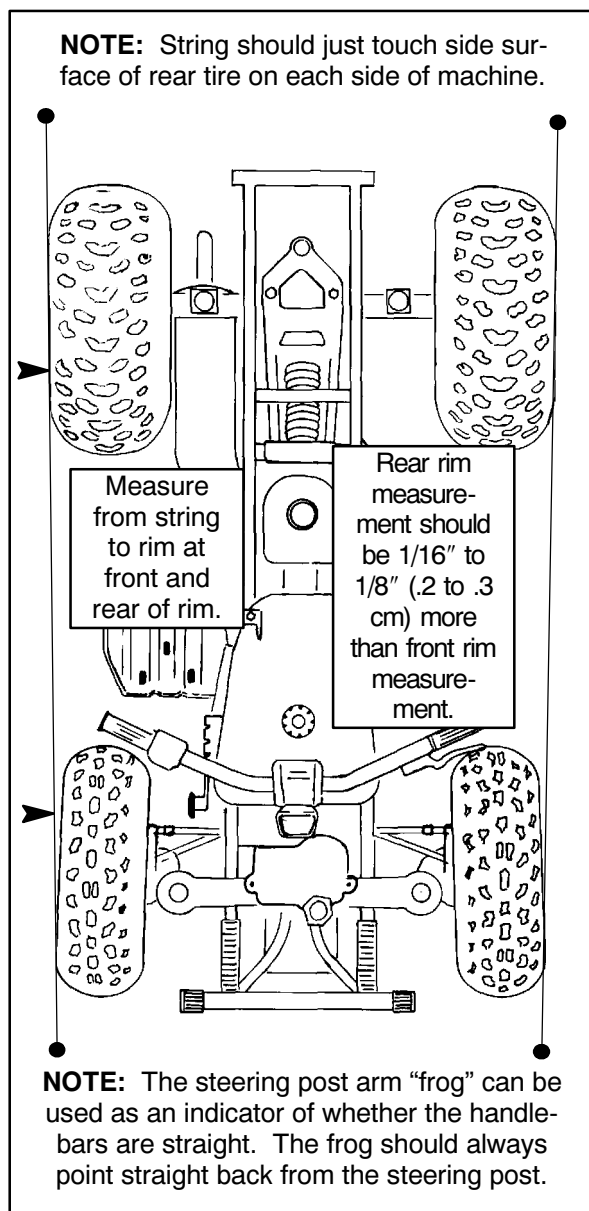

## **WHEEL ALIGNMENT METHOD 2: CHALK**

1. Place machine on a smooth level surface.
2. Set handlebars in a straight ahead position and secure handlebars in this position. **NOTE:** The steering arm "frog" can be used as an indicator of whether the handlebars are straight. The frog should always point straight back from the steering post.
3. Place a chalk mark on the center line of the front tires approximately 10" (25.4 cm) from the floor or as close to the hub/axle center line as possible. **NOTE:** It is important that the height of both marks be equally positioned in order to get an accurate measurement.
4. Measure the distance between the marks and record the measurement. Call this measurement "A".
5. Rotate the tires 180° by moving vehicle forward or backward. Position chalk marks facing rearward, even with the hub/axle centerline.
6. Again measure the distance between the marks and record. Call this measurement "B". Subtract measurement "B" from measurement "A". The difference between measurements "A" and "B" is the vehicle toe alignment. The recommended vehicle toe tolerance is 1/8" to 1/4" (.3 to .6 cm) toe out. This means the measurement at the front of the tire (A) is 1/8" to 1/4" (.3 to .6 cm) wider than the measurement at the rear (B).

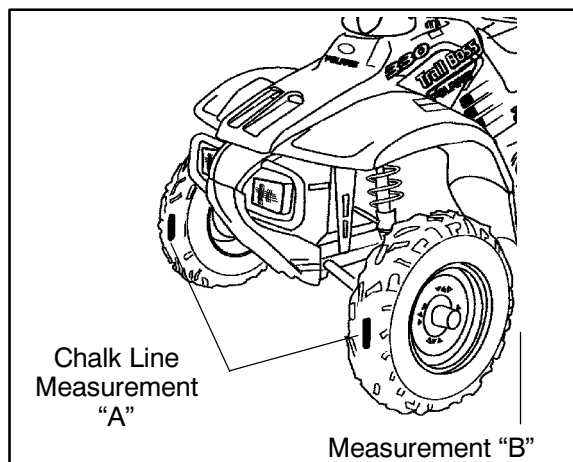



## TOE ALIGNMENT ADJUSTMENT

If toe alignment is incorrect, measure the distance between vehicle center and each wheel. This will tell you which tie rod needs adjusting. **NOTE:** Be sure handlebars are straight ahead before determining which tie rod(s) need adjustment.

**CAUTION:** During tie rod adjustment it is very important that the following precautions be taken when tightening tie rod end jam nuts. If the rod end is positioned incorrectly it will not pivot, and may break.

### To adjust toe alignment:

- Hold tie rod end to keep it from rotating.
- Loosen jam nuts at both end of the tie rod.
- Shorten or lengthen the tie rod until alignment is as required to achieve the proper toe setting. Method 1 (1/16" to 1/8") or Method 2 (1/8" to 1/4").
- **Important:** When tightening the tie rod end jam nuts, the rod ends must be held parallel to prevent rod end damage and premature wear. Damage may not be immediately apparent if done incorrectly. See illustration.

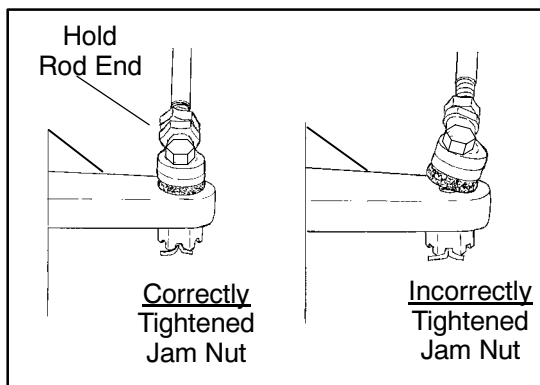

## EXHAUST CLEANING

### **▲ WARNING**

- Do not perform clean out immediately after the engine has been run, as the exhaust system becomes very hot. Serious burns could result from contact with exhaust components.
- To reduce fire hazard, make sure that there are no combustible materials in the area when purging the spark arrestor.
- Wear eye protection.
- Do not stand behind or in front of the vehicle while purging the carbon from the spark arrestor.
- Never run the engine in an enclosed area. Exhaust contains poisonous carbon monoxide gas.
- Do not go under the machine while it is inclined. Set the hand brake and block the wheels to prevent roll back.

Failure to heed these warnings could result in serious personal injury or death.

### **The exhaust pipe must be periodically purged of accumulated carbon as follows:**

1. Remove the clean out plugs located on the bottom of the muffler as shown in illustration 1.

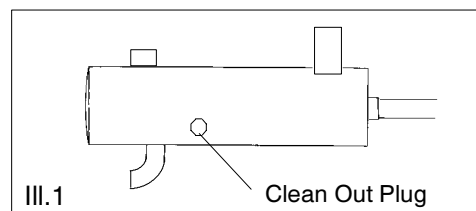

2. Place the transmission in neutral and start the engine. Purge accumulated carbon from the system by momentarily revving the engine several times.
  3. If some carbon is expelled, cover the exhaust outlet and rap on the pipe around the clean out plugs while revving the engine several more times.
  4. If particles are still suspected to be in the muffler, back the machine onto an incline so the rear of the machine is one foot higher than the front. Set the hand brake and block the wheels. Make sure the machine is in neutral and repeat Steps 2 and 3.
- SEE WARNING ABOVE**



5. If particles are still suspected to be in the muffler, drive the machine onto the incline so the front of the machine is one foot higher than the rear. Set the hand brake and block the wheels. Make sure the machine is in neutral and repeat Steps 2 and 3. **SEE PREVIOUS WARNING**
6. Repeat Steps 2 through 5 until no more particles are expelled when the engine is revved.
7. Stop the engine and allow the arrestor to cool.
8. Reinstall the clean out plugs.

## BRAKE SYSTEM INSPECTION

The following checks are recommended to keep the brake system in good operating condition. Service life of brake system components depends on operating conditions. Inspect brakes in accordance with the maintenance schedule and before each ride.

- Keep fluid level in the master cylinder reservoir to the indicated level inside reservoir.
- Use Polaris DOT 3 Brake Fluid (**PN 2870990**).

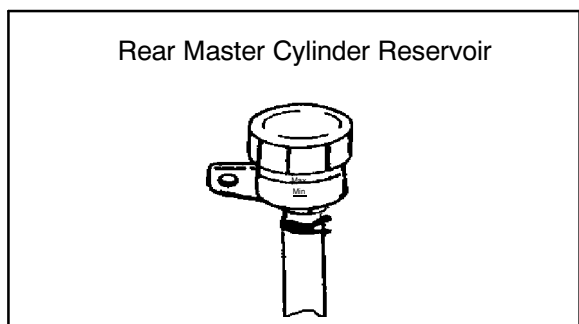
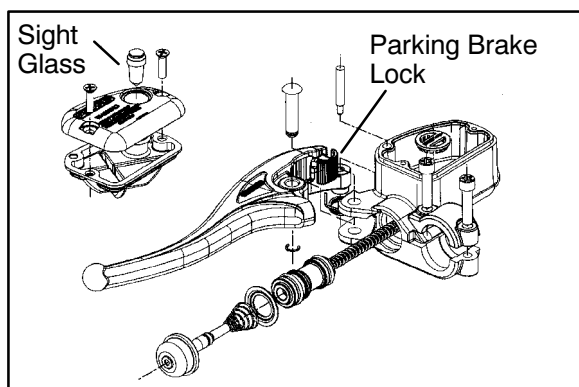

- Check brake system for fluid leaks, excessive travel or spongy feel.
- Check friction pads for wear, damage or looseness.
- Check surface condition of the disc.
- Inspect thickness of brake pad friction material.

## BRAKE PAD INSPECTION

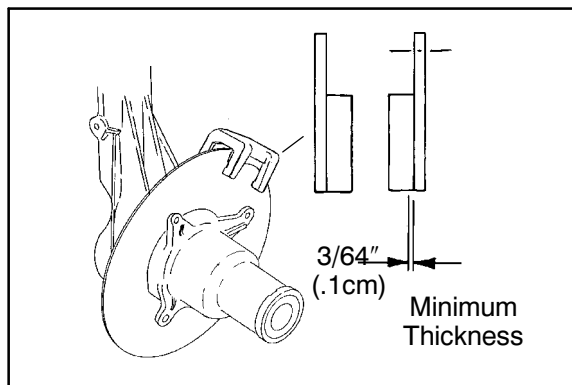

Pads should be changed when friction material is worn to 3/64" (.1 cm), or about the thickness of a dime.

## HOSE/FITTING INSPECTION

Check brake system hoses and fittings for cracks, deterioration, abrasion, and leaks. Tighten any loose fittings and replace any worn or damaged parts.

## AUXILIARY BRAKE ADJUSTMENT (HYDRAULIC)

Use the following procedure to inspect the hydraulic auxiliary (foot) brake system and adjust or bleed if necessary:

First, check foot brake effectiveness by applying 50 lb. (approx.) downward force on the pedal. The top of the pedal should be at least 1 inch, (25.4mm) above the surface of the footrest.

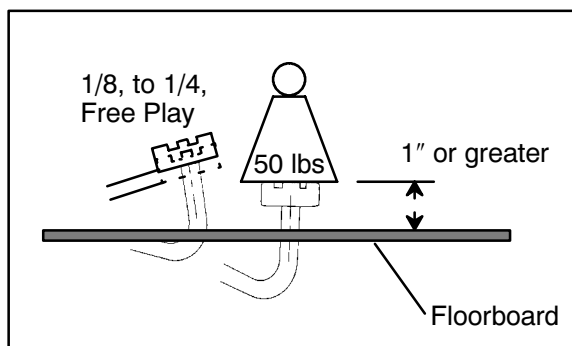





If less than one inch, two things must be examined:

**Free Play:**

**Free play of the brake pedal should be 1/8 - 1/4 inch (3.2 - 6.35 mm).**

If free play is excessive, inspect pedal, linkage, and master cylinder for wear or damage and replace any parts as needed.

**Bleeding:**

If free play is correct and brake pedal travel is still excessive, air may be trapped somewhere in the system. Bleed the hydraulic auxiliary brake system in a conventional manner, following the procedure outlined in Brake Chapter 9.

**DRIVE CHAIN AND SPROCKET INSPECTION**

Polaris ATV drive chains are equipped with O-ring sealed permanently greased pins and rollers. The sprockets and outer rollers require periodic lubrication. Lubricate the chain with Polaris O-Ring Chain Lubricant (PN 2872073).

Inspect the drive chain for missing or damaged O-Rings, link plates, or rollers. Do not wash the chain with a high pressure washer, gasoline or solvents; do not use a wire brush to clean the chain as damage to the O-Rings may occur. Clean chain with hot soapy water and a soft bristled nylon brush.

Never allow battery acid to contact the drive chain.

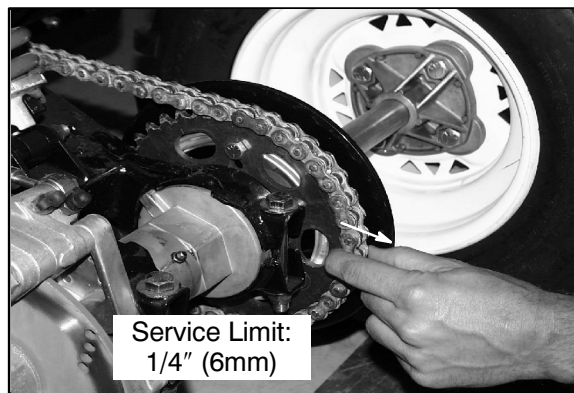

**Drive Chain Lubricant:**  
**Polaris O-Ring Chain Lubricant (PN 2872073)**

**SPROCKET INSPECTION**

Inspect the sprocket for worn, broken or bent teeth.

To check for wear, pull outward on the chain as shown. Replace sprocket if chain movement exceeds 1/4" (.6 cm).

**DRIVE CHAIN INSPECTION**

The chain must be replaced when it reaches 3% elongation.

1. Stretch the chain tightly in a straight line.
2. Measure a length of twenty pitches (pins) from pin center to pin center, and compare to the specification. Replace the chain if the length exceeds the wear limit.
3. When replacing or reinstalling drive chain, install the closed end of the splice link clip as shown, with the closed end leading in forward operation.

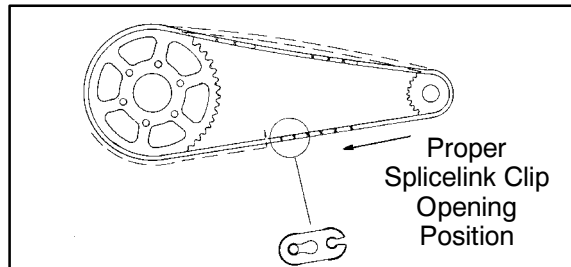

**Drive Chain Wear Limit-20 Pitch Length:**  
**Std: 12.5" (32 cm)**  
**Wear Limit: 12.875" (32.7 cm)**

**DRIVE CHAIN ADJUSTMENT, CONCENTRIC SWINGARM**

**⚠ CAUTION:** Never adjust or operate the vehicle with the rear drive chain too loose or too tight as severe damage to the transmission and drive components can result.

**Break-In:** It is extremely important to maintain proper chain tension to ensure the best possible chain life. There is a chain break-in period of approximately 100 miles or two (2) tanks of fuel. During this time chain tension should be watched very closely and loads to the chain should be kept light.

**Checking Deflection:** Inspect chain deflection by slowly moving the ATV forward so any slack that may have previously been on the under part of the chain is now on the top side of the chain. The bottom part of the chain should be taught during inspection. Measure the chain deflection as shown in the diagram. **Deflection should be approximately 3/8 in. (10 mm).**



After inspection, again slowly move the ATV forward until all the chain slack is on the top side of the chain and inspect the deflection. Repeat this procedure several times to check different spots on the chain.

The chain is correctly adjusted when the tightest portion of the chain itself has approximately 3/8 in., (10 mm) of deflection. It's a common characteristic of any chain to have one or more tight spots in the chain. Therefore, it is extremely important to check chain deflection in several areas of the chain to ensure deflection is correct at the tightest point.

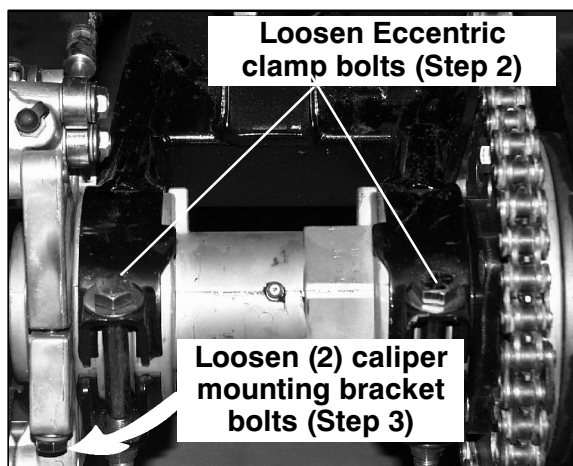
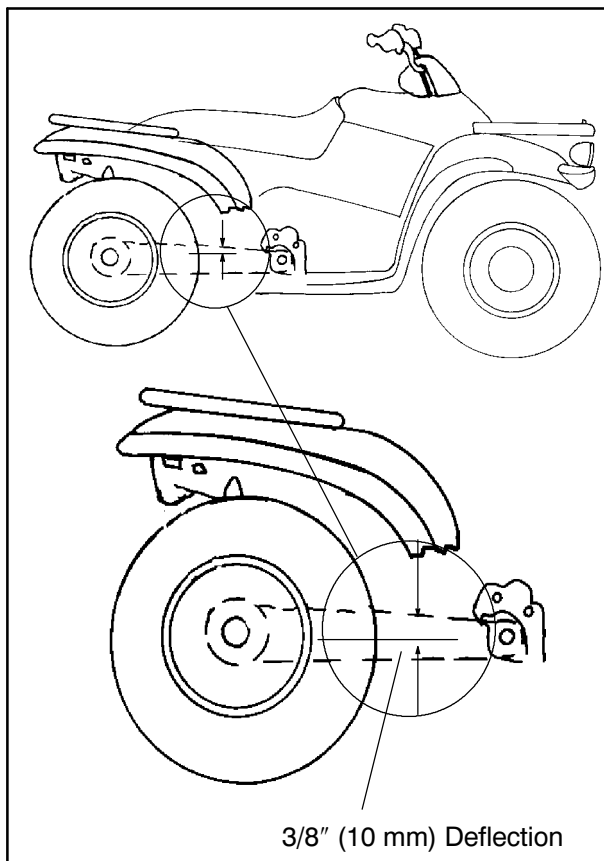

4. Insert a pin punch through the sprocket hub and into the eccentric axle housing.
5. Move the ATV forward or back to move the eccentric housing and adjust to the proper tension (Approximately: 3/8" , or 10 mm)

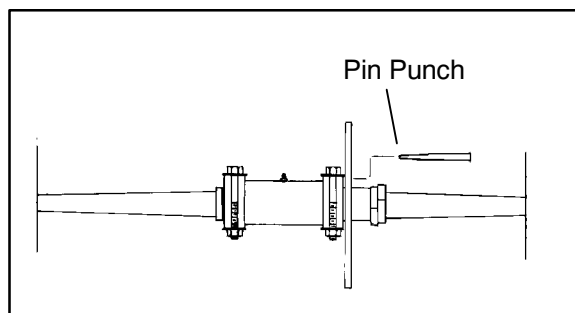

6. Tighten the eccentric clamp bolts to specification.

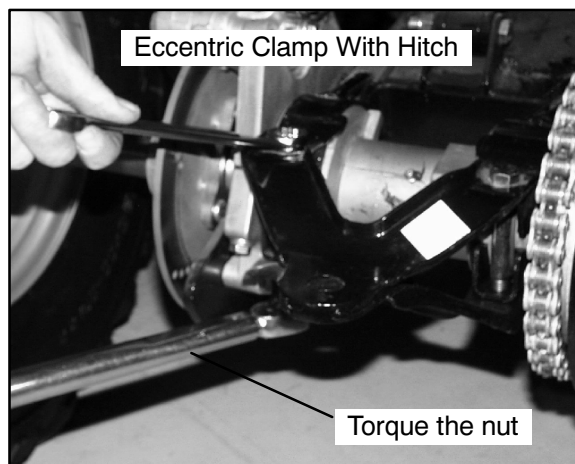

**WITH TRAILER HITCH - 45 ft. lbs. (61 Nm)**

## ADJUSTMENT PROCEDURE - CONCENTRIC SWINGARM

1. Loosen chain guide.
2. Loosen the two (2) eccentric clamp bolts.
3. Loosen caliper mounting bracket bolts located under the axle.

See illustration for bolt locations.



**CAUTION: DO NOT OVER-TIGHTEN ECCENTRIC CLAMP BOLTS. PRE-MATURE BEARING FAILURE MAY RESULT.**

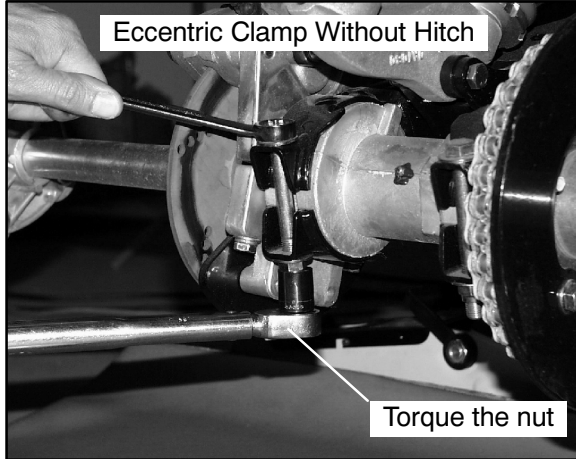

**WITHOUT TRAILER HITCH - 30 ft. lbs. (41 Nm)**

7. Tighten caliper mounting bracket bolts 10-12 ft. lbs. (14 - 17 Nm)

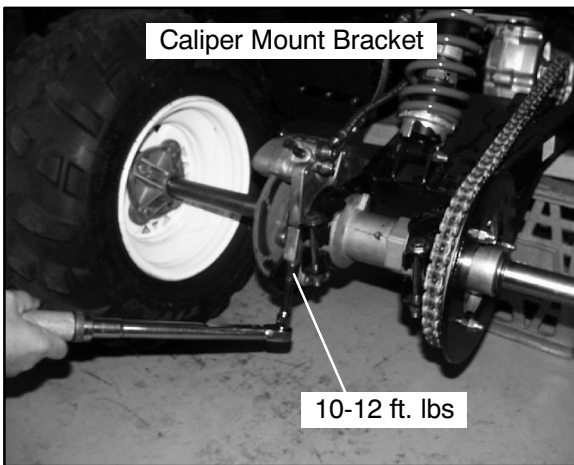

8. Remove pin punch.
9. Roll ATV forward checking chain tension at the same point in several places around the chain. **The chain is adjusted correctly when the tightest portion of the chain has approximately 3/8 in. (10 mm) of deflection.**
10. Position chain guide to allow 1/8" (3.175 mm), clearance and tighten retaining bolt to 5 ft.lbs (7 Nm).

The chain can also be adjusted by loosening the rear eccentric housing as described previously and using a 2 1/2" (63.5 mm) wrench on the flats of the eccentric. Turn the eccentric with the wrench until chain tension is to specification.

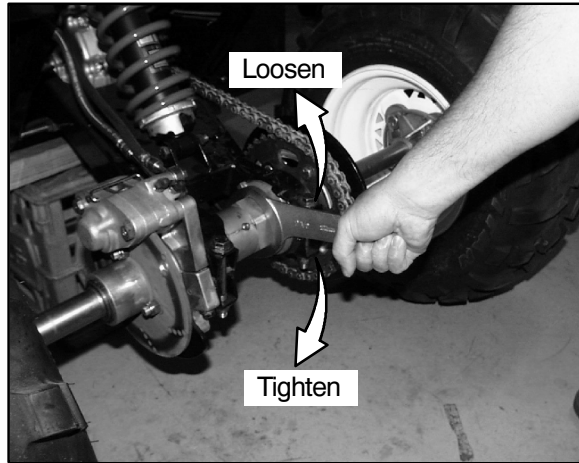

## **SUSPENSION SPRING PRELOAD ADJUSTMENT**

Operator weight and vehicle loading affect suspension spring preload requirements. Adjust as necessary to avoid bottoming of the shocks.

## **FRONT SUSPENSION**

Compress and release front suspension. Damping should be smooth throughout the range of travel.

Check all front suspension components for wear or damage.

Inspect front strut cartridges for leakage.

## **REAR SUSPENSION**

Compress and release rear suspension. Damping should be smooth throughout the range of travel.

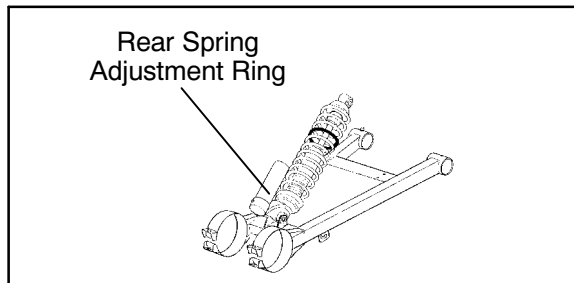

- Check all rear suspension components for wear or damage.
- Inspect shock for leakage.

**Shock Spanner Wrench**  
**(PN 2870872)**



## CONTROLS

Check controls for proper operation, positioning and adjustment.



- Brake control and switch must be positioned to allow brake lever to travel throughout entire range without contacting switch body.

## WHEELS

Inspect all wheels for runout or damage. Check wheel nuts and ensure they are tight. Do not over tighten the wheel nuts.

## WHEEL, HUB, AND SPINDLE TORQUE TABLE

Item	Specification
Front Wheel Nuts	20 Ft. Lbs. (27 Nm)
Rear Wheel Nuts	50 Ft. Lbs. (68 Nm)
Front Spindle Nut	40 Ft Lbs. (54Nm)
Rear Hub Retaining Nut	80 Ft. Lbs. (108 Nm)

## WHEEL REMOVAL FRONT OR REAR

1. Stop the engine, place the transmission in gear and lock the parking brake.
2. Loosen the wheel nuts slightly.
3. Elevate the side of the vehicle by placing a suitable stand under the footrest frame.

4. Remove the wheel nuts and remove the wheel.

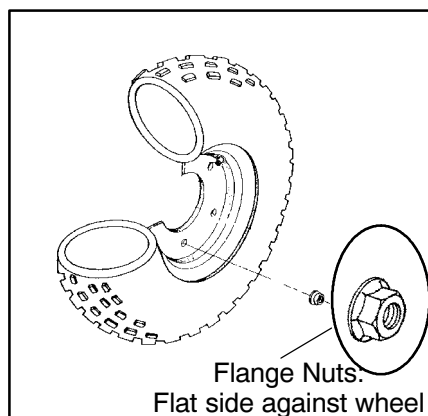
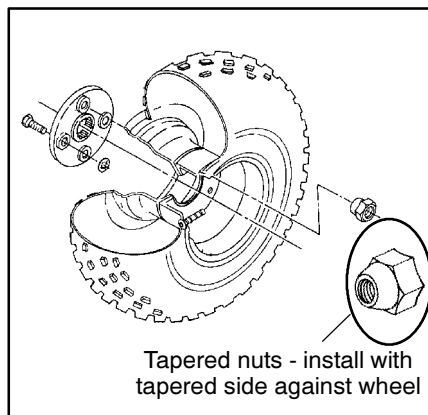

## WHEEL INSTALLATION

1. With the transmission in gear and the parking brake locked, place the wheel in the correct position on the wheel hub. Be sure the valve stem is toward the outside and rotation arrows on the tire point toward forward rotation.
2. Attach the wheel nuts and finger tighten them.
3. Lower the vehicle to the ground.
4. Securely tighten the wheel nuts to the proper torque listed in the table above.

**CAUTION:**

If wheels are improperly installed it could affect vehicle handling and tire wear. On vehicles with tapered rear wheel nuts, make sure tapered end of nut goes into taper on wheel.



## TIRE PRESSURE

Tire Pressure Inspection (PSI - Cold)	
Front	Rear
4	3

## TIRE INSPECTION

### **▲ WARNING**

Operating an ATV with worn tires will increase the possibility of the vehicle skidding and possible loss of control.

Worn tires can cause an accident.

Always replace tires when the tread depth measures 1/8" (.3 cm) or less.

#### **CAUTION:**

- Maintain proper tire pressure. Refer to the warning tire pressure decal applied to the vehicle.
- Improper tire inflation may affect ATV maneuverability.
- When replacing a tire always use original equipment size and type.
- The use of non-standard size or type tires may affect ATV handling.

#### **Tire Tread Depth**

Always replace tires when tread depth is worn to 1/8" (3 mm) or less.

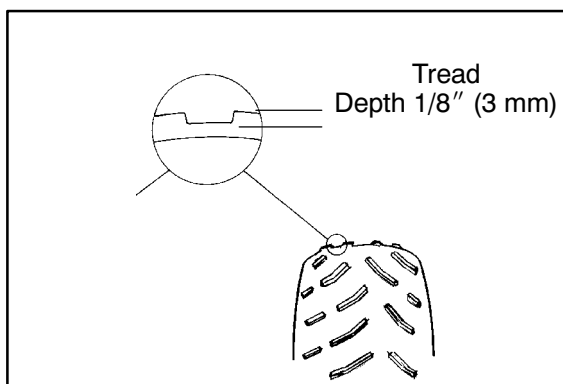

## FRAME, NUTS, BOLTS, FASTENERS

Periodically inspect the tightness of all fasteners in accordance with the maintenance schedule. Check that all cotter pins are in place. Refer to specific fastener torques listed in each chapter.



## ***CHAPTER 3*** **ENGINE**

Engine Service Data .....	3.2-3.3
Special Tools and Torque Specifications .....	3.4
Torque Patterns .....	3.4
Piston Identification .....	3.5
Engine Removal .....	3.5
Engine Installation Notes .....	3.6
Cylinder Honing .....	3.6-3.7
Engine Lubrication .....	3.7
Oil Pressure Test .....	3.7-3.8
Lubrication/Oil Flow .....	3.8-3.9
Engine Exploded View .....	3.10
Engine Top End Disassembly .....	3.11-3.18
Valve/ Valve Seat Service .....	3.18-3.22
Engine Bottom End Disassembly .....	3.22-3.32
Crankcase & Bearing Assembly .....	3.32
Crankshaft End Play Inspection .....	3.32-3.33
Engine Assembly/Inspection .....	3.33-3.42
Recoil Disassembly/Inspection/Reassembly ....	3.42-3.44
Spark Plug Fouling Checklist .....	3.45
Troubleshooting .....	3.45-3.46



## ES32PFE10 ENGINE SERVICE DATA

Cylinder Head / Valve				ES32PFE10		
Rocker Arm	Rocker arm ID			.8669-.8678" (22.020-22.041 mm)		
	Rocker shaft OD			.8656-.8661" (21.987-22.0 mm)		
	Rocker shaft Oil Clearance		Std	.0008-.0021" (.020-.054 mm)		
			Limit	.0039" (.10 mm)		
Camshaft	Cam lobe height	In	Std	1.3001-1.3041" (33.023-33.123 mm)		
			Limit	1.2883" (32.723 mm)		
		Ex	Std	1.3007-1.3047" (33.039-33.139 mm)		
			Limit	1.2889" (32.739 mm)		
	Camshaft journal OD		Mag	1.4935-1.4941" (37.935-37.950 mm)		
			PTO	1.4935-1.4941" (37.935-37.950 mm)		
	Camshaft journal bore ID		Mag	1.4963-1.4970" (38.005-38.025 mm)		
			PTO	1.4963-1.4970" (38.005-38.025 mm)		
	Camshaft Oil clearance		Std	.0022-.0035" (.055-.090 mm)		
			Limit	.0039" (.10 mm)		
Cylinder Head	Surface warpage limit			.0020" (.05 mm)		
	Standard height			2.908" (73.8 mm)		
Valve Seat	Contacting width	In	Std	.039" (1.0 mm)		
			Limit	.055" (1.4 mm)		
		Ex	Std	.059" (1.5 mm)		
			Limit	.071" (1.8 mm)		
Valve Guide	Inner diameter			.2362-.2367" (6.000-6.012 mm)		
	Protrusion above head			.681-.689" (17.3-17.5 mm)		
Valve	Margin thickness	In	Std	.039" (1.0 mm)		
			Limit	.032" (0.8 mm)		
		Ex	Std	.047" (1.2 mm)		
			Limit	.032" (0.8 mm)		
Valve	Stem diameter		In	.2343-.2348" (5.950-5.965 mm)		
			Ex	.2341-.2346" (5.945-5.960 mm)		
	Stem oil clearance		Std	In	0.0014-0.0024" (0.035-0.062mm)	
				Ex	0.0016-0.0026" (0.040-0.067mm)	
			Limit	.0059" (0.15 mm)		
	Overall length		In	3.979" (101.0 mm)		
			Ex	3.987" (101.2 mm)		
	Valve Spring	Free length		Std	1.673" (42.5 mm)	
Limit				---		
Squareness		0.075" (1.9 mm)				



**ES32PFE10 ENGINE SERVICE  
DATA**

Cylinder / Piston / Connecting Rod				ES32PFE10	
Cylinder	Surface warpage limit (mating with cylinder head)			.0020" (0.050 mm)	
	Cylinder bore		Std	3.0906-3.0913" (78.50-78.520 mm)	
	Taper limit			.0020" (0.050 mm)	
	Out of round limit			.0020" (0.050 mm)	
	Piston clearance		Std	.0015-.0032" (0.038-0.082 mm)	
			Limit	.004" (0.11 mm)	
Boring limit			.0020" (0.5 mm)		
Piston	Outer diameter	Std	3.0881-3.0891" (78.438-78.462 mm)		
		.0098" (.25 mm) OS	3.0980-3.0989" (78.688-78.712 mm)		
		.0197" (.50 mm) OS	3.1078-3.1087" (78.938-78.962 mm)		
	Standard inner diameter of piston pin bore		.7095-.7097" (18.007-18.013 mm)		
Piston Pin	Outer diameter			.7092-.7095" (18.001-18.007 mm)	
	Standard clearance-piston pin to pin bore			0.0-.0005" (0.0-0.012 mm)	
	Degree of fit			Piston pin must be a push (by hand) fit at 68° F (20° C)	
Piston Ring	Piston ring installed gap	Top ring	Std	.0079-.0118" (0.20-0.30 mm)	
			Limit	.039" (1.0 mm)	
		Second ring	Std	.0138-.0197" (0.35-0.50 mm)	
			Limit	.039" (1.0 mm)	
		Oil ring	Std	.0079-.0236" (0.20-0.60 mm)	
			Limit	.059" (1.5 mm)	
Piston Ring	Standard clearance - piston ring to ring groove	Top ring	Std	.0014-.0030" (0.035-0.075 mm)	
			Limit	.0059" (0.15 mm)	
		Second ring	Std	.0010-.0026" (0.025-0.065 mm)	
			Limit	.0059" (0.15 mm)	
Connecting Rod	Connecting rod small end ID			.7095-.7101" (18.007-18.023 mm)	
	Connecting rod small end radial clearance		Std	0.0-.0009" (0.0-0.022 mm)	
			Limit	.0012" (0.03 mm)	
	Connecting rod big end side clearance		Std	.0028-.0118" (0.07-0.30 mm)	
			Limit	.0138" (0.35 mm)	
	Connecting rod big end bearing clearance		Std	0.0007-0.0021" (0.019-0.053 mm)	
Limit			0.0026" (0.065 mm)		
Crankshaft	Crankshaft runout limit (PTO end)			0.0024" (0.060 mm)	
	Crankshaft end play			0.002-0.008" (0.05-0.20 mm)	

KEY - Std: Standard; OS: Oversize; ID: Inner Diameter;  
 OD: Outer Diameter; Mag: Magneto Side; PTO: Power  
 Take Off Side





**SPECIAL TOOLS**

PART NUMBER	TOOL DESCRIPTION
2200634	Valve Seat Reconditioning Kit
2870390	Piston Support Block
2870159	Flywheel Puller
2871293	Slotted Nut Socket
PV-43527	Oil Filter Wrench

**TORQUE SPECIFICATIONS**

ENGINE TORQUE SPECIFICATIONS		
Fastener	Size	330 ES32PFE10 Ft. Lbs. (Nm)
Camshaft Chain Tensioner Lever	6mm	5-6.5 (7-9 Nm)
Camshaft Chain Tensioner	6mm	5-6.5 (7-9 Nm)
Camshaft Chain Tensioner Cap	11mm	8-10 (11-14 Nm)
Camshaft Sprocket	10mm	25-29 (34-40 Nm)
Carburetor Adaptor	8mm	12-14 (16-20 Nm)
Connecting Rod	8.5mm	29-33 (39-45 Nm)
Crankcase	8mm	14-15 (19-21 Nm)
Crankshaft Slotted Nut (Drive Sprocket)	28mm	35-51 (47-69 Nm)
Cylinder Base Bolts	6mm	5-7 (7-9 Nm)
Cylinder Head Bolts	10mm	Refer to Engine Assembly for torque procedure
Drive Clutch Bolt	7/16 - 20	40 (55 Nm)
Flywheel	16mm	58-72 (78-98 Nm)
Oil Hose Fittings	1/2 & 9/16	20 (27 Nm)
Oil Delivery Pipe	12mm	11-15 (15-21 Nm)
Oil Drain Bolt (Crankcase)	14mm	14-17 (19-23 Nm)
Oil Filter Pipe Fitting (Connector)	20mm	36-43 (49-59 Nm)

Oil Line Fitting		20 (27 Nm)
Oil Pump Cover	6mm	4-5 (5-7 Nm)
Oil Relief Valve Plug	14mm	14.5-16.5 (20-23 Nm)
Recoil Housing	6mm	5-6.5 (7-9 Nm)
Rocker Cover	6mm	7-8 (9-11 Nm)
Rocker Cover Block Plug	28mm	39-44 (53-59)
Rocker Adjuster Screw Lock Nut	6mm	6-7 (8-10 Nm)
Stator Plate	6mm	5-6.5 (7-9 Nm)
Starter Motor	6mm	5-6.5 (7-9 Nm)
Spark Plug	14mm	9-11 (12-15 Nm)

**ENGINE FASTENER TORQUE PATTERNS**

Tighten cylinder head, cylinder base, and crankcase fasteners in 3 steps following the sequence outlined below.

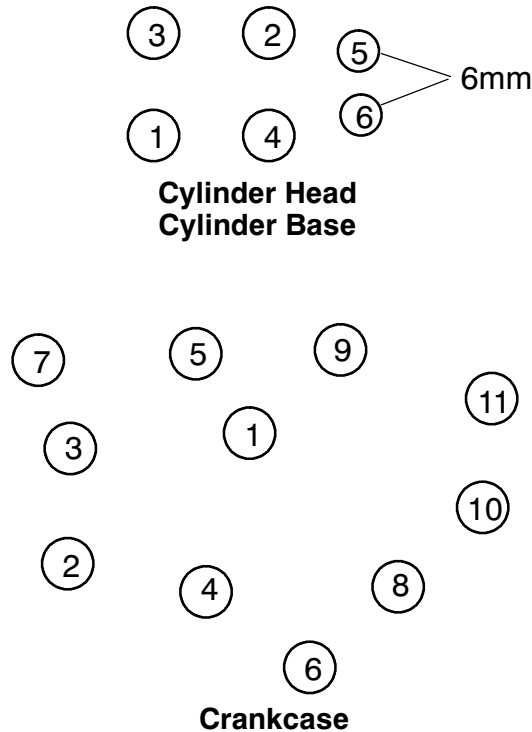



## PISTON IDENTIFICATION

The piston may have an identification mark or the piston may not have an identification mark for piston placement. If the piston has an identification mark, follow the directions for piston placement below. If the piston does not have an identification mark, the direction for placement of the piston does not matter.

Note the directional and identification marks when viewing the pistons from the top. The letter “F”, “→”, “▶” or “■” must always be toward the flywheel side of the engine. The other numbers are used for identification as to diameter, length and design. Four stroke engine rings are rectangular profile. The numbers or letters on all rings (except oil control rings) must be positioned upward. See text for oil control ring upper rail installation. Use the information below to identify pistons and rings.

Engine Model No.	Oversize Available* (mm)	Standard Piston Identification
ES32PFE	.25 .50	None

\*Pistons and rings marked 25 are .25mm (.010”) oversized. Pistons and rings marked 50 are .50mm (.020”) oversized

## ACCESSIBLE COMPONENTS

The following components can be serviced or removed with the engine installed in the frame:

- Flywheel
- Alternator/Stator
- Starter Motor/Starter Drive
- Cylinder Head
- Cylinder
- Piston/Rings
- Oil pump
- Rocker Arms
- Cam Chain and Sprockets

The following components require engine removal for service:

- Camshaft
- Connecting Rod
- Crankshaft
- Crankshaft Main Bearings
- Crankcase

## ENGINE REMOVAL

1. Clean work area.
2. Thoroughly clean the ATV engine and chassis.
3. Disconnect battery negative (-) cable.
4. Remove the following parts as required.
  - Seat
  - Left and Right Side Covers (Refer to Chapter 5)
  - Fuel Tank Cover / Front Cab (Refer to Chapter 5)
  - Fuel Tank (Refer to Chapter 4)
5. Disconnect spark plug high tension lead.
6. Disconnect all electrical wires from the engine.
7. Remove springs from exhaust pipe and remove pipe.
8. Drain engine oil.
9. Remove airbox.
10. Remove carburetor. Insert a shop towel into the carburetor flange to prevent dirt from entering the intake port.
11. Loosen auxiliary brake master cylinder mount if necessary for clearance.
12. Refer to PVT System Chapter 6 to remove outer clutch cover, drive belt, drive clutch, driven clutch, and inner cover.
13. Starter motor. Note ground cable location. Mark positive (+) cable mounting angle and remove cable.
14. Remove transmission linkage rod(s) from gear selector and secure out of the way.
15. Remove engine to chassis ground cable.
16. Remove all engine mount nuts and / or engine mount plates.
17. Remove engine through right side of frame.



## ENGINE INSTALLATION

### NOTES

After the engine is installed in the frame, review this checklist and perform all steps that apply.

#### General Items

- Install previously removed components using new gaskets, seals, and fasteners where applicable.
- Perform regular checks on fluid levels, controls, and all important areas on the vehicle as outlined in the daily pre-ride inspection checklist (refer to Chapter 2).

#### PVT System

- Adjust center distance of drive and driven clutch. (Chapter 6)
- Adjust clutch offset, alignment, and belt deflection. (Chapter 6)
- Clean clutch sheaves thoroughly and inspect inlet and outlet ducts for proper routing and sealing. (Chapter 6)

#### Transmission

- Inspect transmission operation and adjust linkage if necessary. Refer to Chapter 2 and Chapter 8.

#### Exhaust

- Replace exhaust gaskets. Seal connections with high temp silicone sealant.
- Check to be sure all springs are in good condition.

#### Engine Break In Period

4 Cycle Engine Break-In Period is defined as the first 10 hours of engine operation or 2 full tanks of fuel.

- Use only Polaris Premium 4 All Season Synthetic Oil, or API certified "SH" oil.
- Use fuel with a minimum octane of 87 (R+M)/2 method.
- Change break-in oil and filter at 20 hours or 500 miles, whichever comes first.

## CYLINDER HONE

### SELECTION/HONING

### PROCEDURE

#### CAUTION:

A hone which will straighten as well as remove material from the cylinder is very important. Using a common spring loaded glaze breaker for honing is not advised for nicasil cylinders. Polaris recommends using a rigid hone or arbor honing machine.

Cylinders may be wet or dry honed depending upon the hone manufacturer's recommendations. Wet honing removes more material faster and leaves a more distinct pattern in the bore.

### HONING TO DEGLAZE

A finished cylinder should have a cross-hatch pattern to ensure piston ring seating and to aid in the retention of the fuel/oil mixture during initial break in. Hone cylinder according to hone manufacturer's instructions, or these guidelines:

- Use a motor speed of approximately 300-500 RPM, run the hone in and out of the cylinder rapidly until cutting tension decreases. Remember to keep the hone drive shaft centered (or cylinder centered on arbor) and to bring the stones approximately 1/2" (1.3 cm) above and below the bore at the end of each stroke.
- Release the hone at regular intervals and inspect the bore to determine if it has been sufficiently deglazed, and to check for correct cross-hatch.
 

**NOTE: Do not allow cylinder to heat up during honing.**
- After honing has been completed, inspect cylinder for thinning or peeling.

#### **IMPORTANT: Clean the Cylinder After Honing**

It is very important that the cylinder be thoroughly cleaned after honing to remove all grit material. Wash the cylinder in a solvent, then in hot, soapy water. Use electrical contact cleaner if necessary to clean these areas. Rinse thoroughly, dry with compressed air, and oil the bore immediately with Polaris 4 Cycle Lubricant to prevent the formation of surface rust.



If cylinder wear or damage is excessive, it will be necessary to replace the cylinder. Hone only enough to deglaze the outer layer of the cylinder bore.

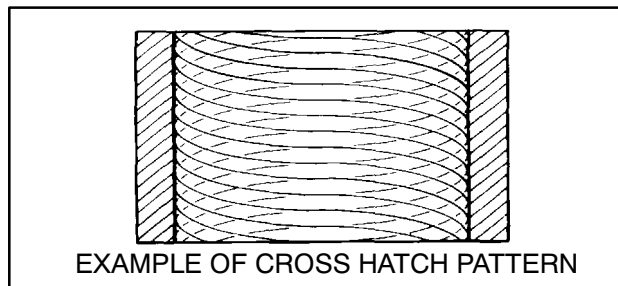

## HONING TO OVERSIZE

If cylinder wear or damage is excessive, it will be necessary to oversize the cylinder using a new oversize piston and rings. This may be accomplished by either boring the cylinder and then finish honing to the final bore size, or by rough honing followed by finish honing.

For oversize honing always wet hone using honing oil and a coarse roughing stone. Measure the piston (see piston measurement) and rough hone to the size of the piston. Always leave .002 - .003" (.05 - .07 mm) for finish honing. Refer to piston-to-cylinder clearance specifications on **Page 3.2** before honing. Complete the sizing with fine grit stones to provide the proper cross-hatch finish and required piston clearance.

A finished cylinder should have a cross-hatch pattern to ensure piston ring seating and to aid in the retention of the fuel/oil mixture during initial break in. Hone cylinder according to hone manufacturer's instructions, or these guidelines:

- Use a motor speed of approximately 300-500 RPM, run the hone in and out of the cylinder rapidly until cutting tension decreases. Remember to keep the hone drive shaft centered (or cylinder centered on arbor) and to bring the stone approximately 1/2" (1.3 cm) beyond the bore at the end of each stroke.
- Release the hone at regular intervals and inspect the bore to determine if it has been cleared, and to check piston fit. **NOTE:** Do not allow cylinder to heat up during honing. The thinner areas of the liner around the ports will expand causing an uneven bore.
- After honing has been completed inspect all port opening areas for

rough or sharp edges. Apply a slight chamfer to all ports to remove sharp edges or burrs, paying particular attention to the corners of the intake and exhaust ports.

### **IMPORTANT: Clean the Cylinder After Honing**

It is very important that the cylinder be thoroughly cleaned after honing to remove all grit material. Wash the cylinder in a solvent, then in hot, soapy water. Use electrical contact cleaner if necessary to clean these areas. Rinse thoroughly, dry with compressed air, and oil the bore immediately with Polaris 4 Cycle Lubricant to prevent the formation of surface rust.

## ENGINE LUBRICATION - ES32PF10

**Oil Type** . . . . . Polaris Premium 0-40W Synthetic (PN 2871281)

**Capacity** . . . . . Approximately 2 U.S. Quarts (1.9 l)

**Filter** . . . . . PN 3084963

**Oil Filter Wrench** . . . . . PV-43527

**Drain Plug/Screen Fitting** . . . . . 14 ft. lbs. (19 Nm)

**Oil Pressure Specification (ES32PF10)** . . . . . 71-99 PSI @ 3000 RPM, Polaris 0W-40 Synthetic (Oil temp at 122°F 50°C)

## OIL PRESSURE TEST ES32PF10

**WARNING:** *Oil temperature and pressure can cause serious injury and damage. Wear the proper safety gear when performing these procedures.*

1. Remove lower blind plug behind oil filter on crankcase.
2. Insert a 1/8" NPT oil pressure gauge adaptor into the crankcase and attach gauge.



3. Start engine and allow it to reach operating temperature while monitoring gauge indicator.

**NOTE:** Use Polaris Premium 0-40W Synthetic Engine Lubricant (PN 2871281).

**ES32PF10**  
**Oil Pressure at 3000 RPM (Engine Hot):**  
Standard: 71-99 PSI  
Minimum: 20 PSI at idle

## OIL COOLER ASSEMBLY

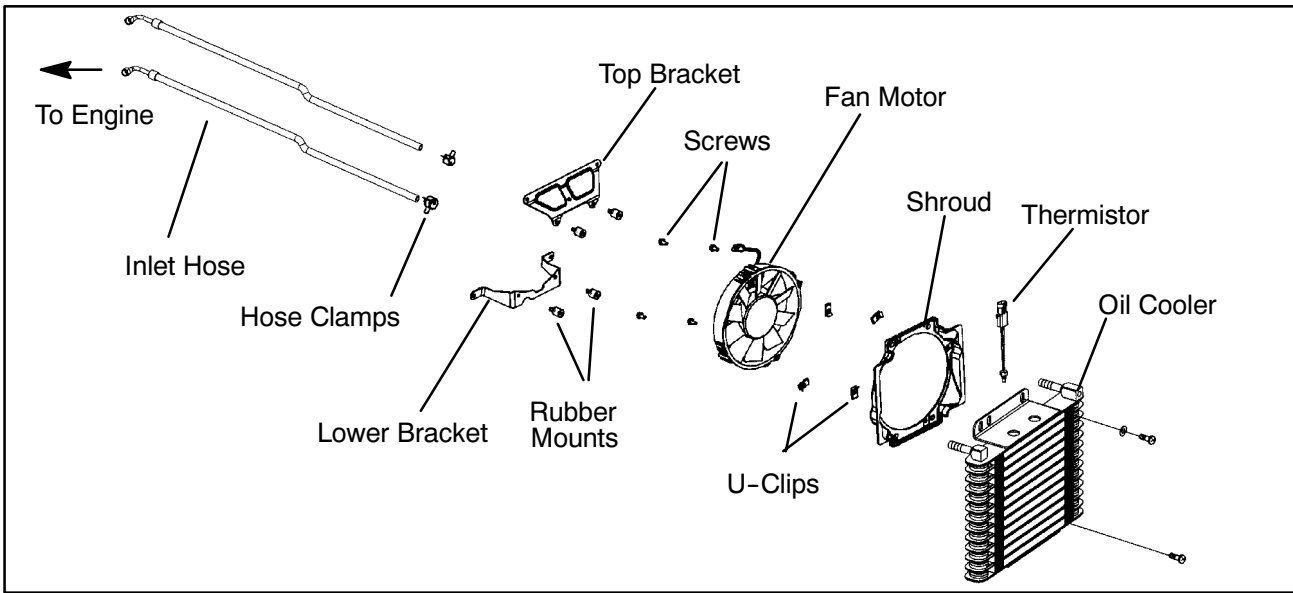



# OIL FLOW DIAGRAM - ES32PF

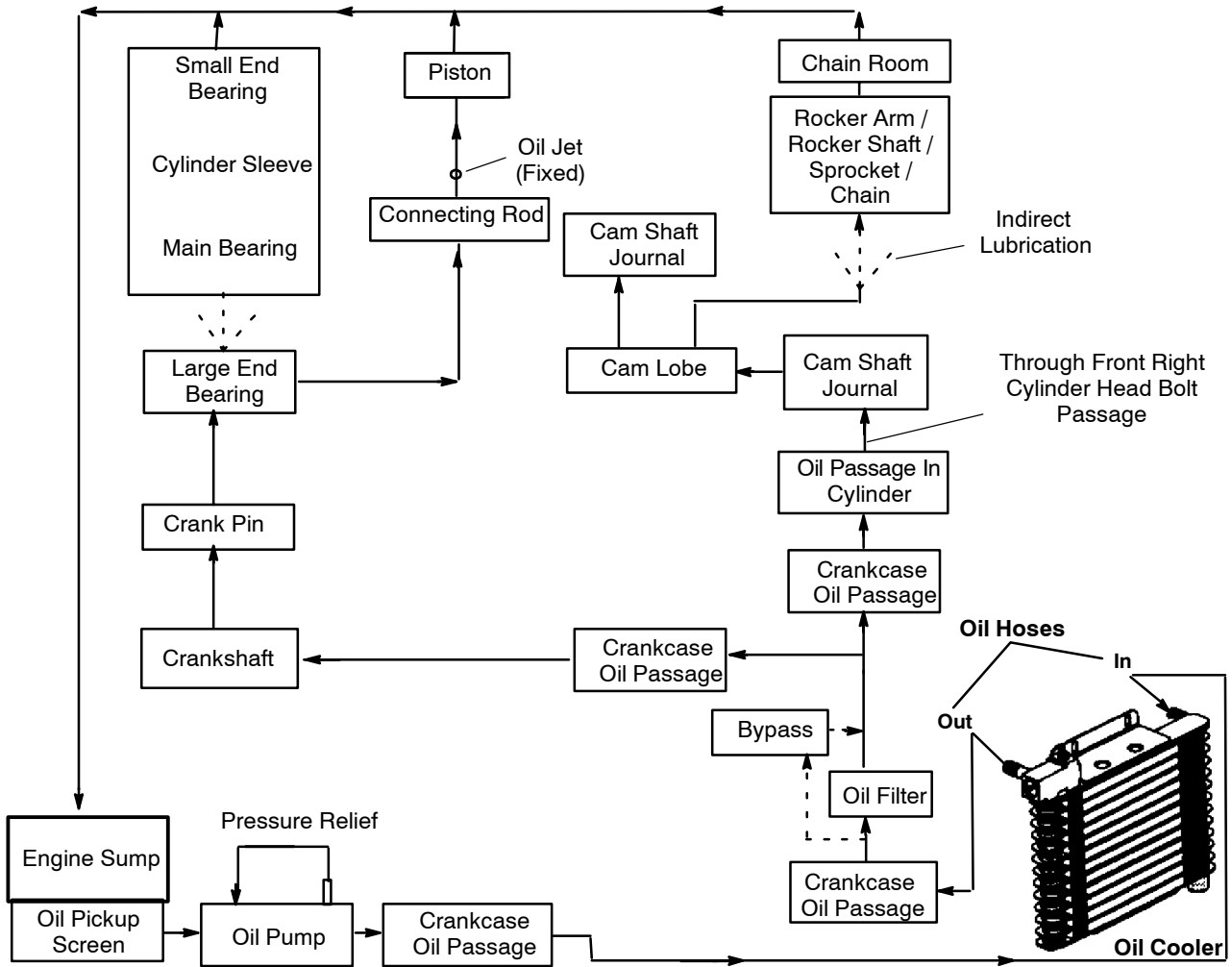



# ES32PFE ENGINE EXPLODED VIEW

**Crankcase**  
ES32PF

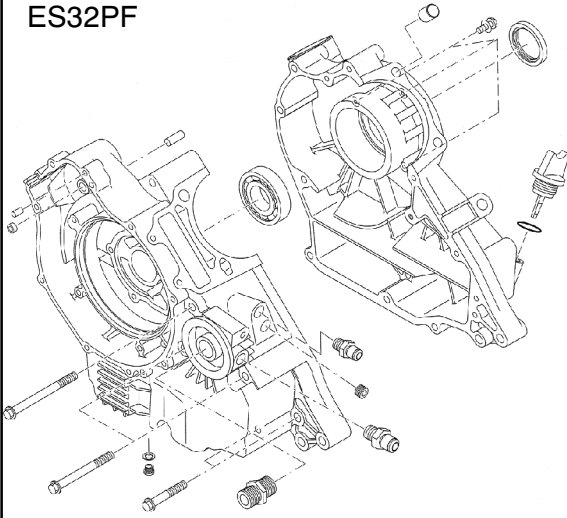

**Cylinder/  
Cylinder Head**

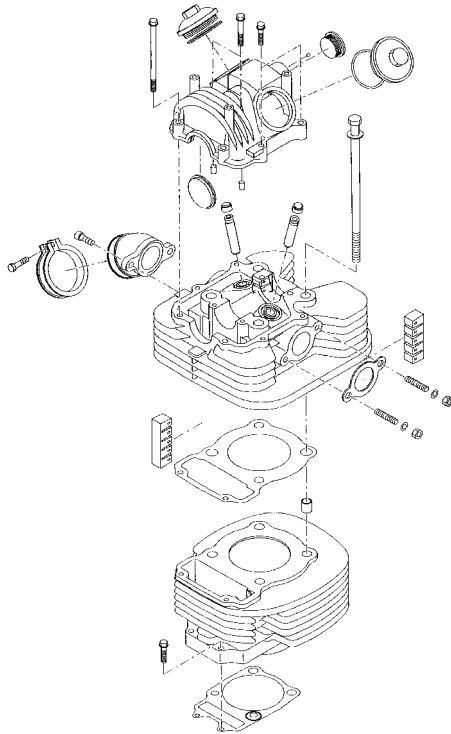

**Crankshaft  
and Piston**

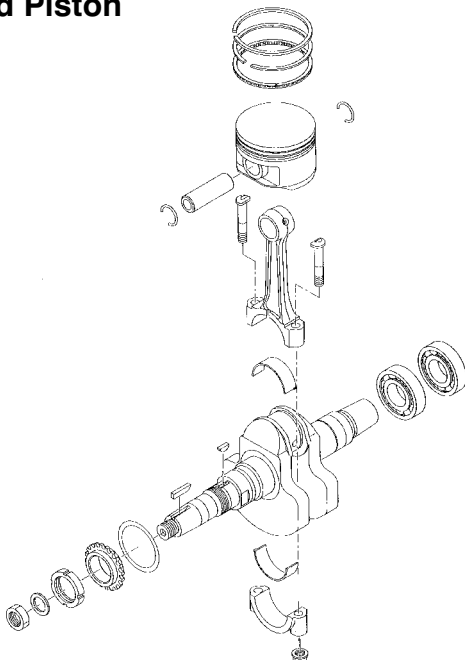

**Valve Train**

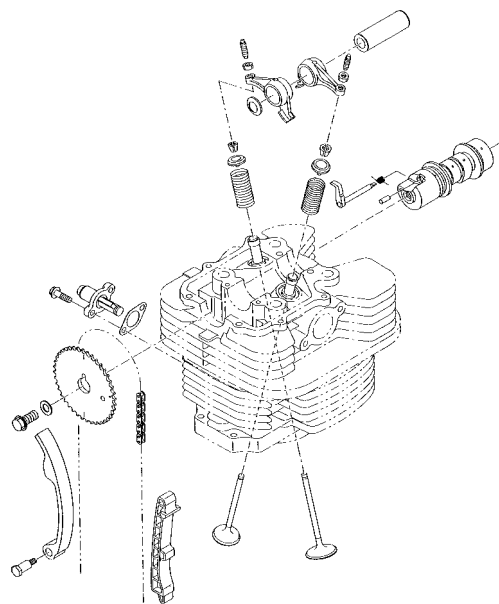



## ENGINE REMOVAL

**REFER TO PAGE 3.5 - 3.6 FOR ENGINE  
REMOVAL / INSTALLATION NOTES.**

## CAM CHAIN TENSIONER REMOVAL

1. Remove ignition timing inspection plug from recoil housing.

**To position crankshaft at Top Dead Center (TDC)  
on compression stroke:**

2. Rotate engine slowly in the direction of rotation watching intake valves open and start to close.
3. Continue to rotate engine slowly, watching camshaft sprocket marks and the mark in the timing inspection hole.

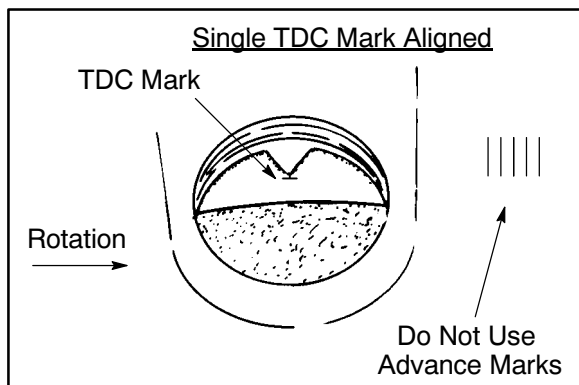

4. Align single (TDC) mark on flywheel with projection in inspection hole, and the cam sprocket pin (facing upward) aligned with the camshaft to crankshaft center line. **NOTE:** The sprocket marks align with gasket surface and the cam lobes should be pointing down and valves should have clearance at this point.

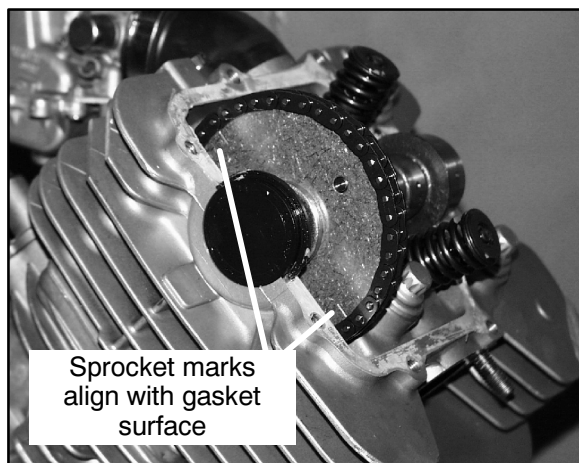

5. Remove cam chain tensioner plug, sealing washer, spring and pin. **CAUTION:** The plug is under spring tension. Maintain inward pressure while removing.
6. Remove the two 6x25 mm cam chain tensioner flange bolts.
7. Tap lightly on tensioner body with a soft face hammer and remove tensioner.



## CAM CHAIN TENSIONER INSPECTION

1. Pull cam chain tensioner plunger outward to the end of its travel. Inspect teeth on ratchet pawl (A) and plunger teeth (B) for wear or damage.

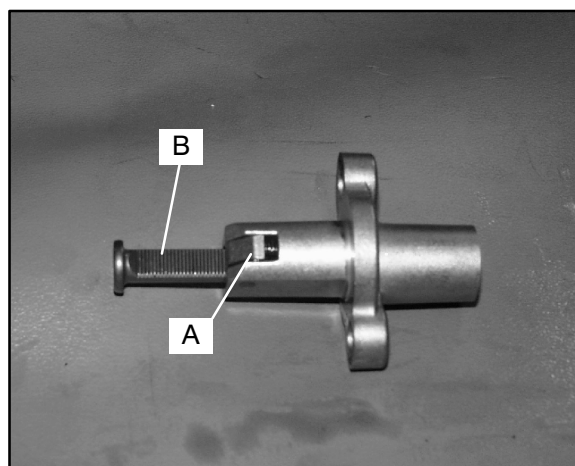

2. Push ratchet pawl and hold it. The plunger should move smoothly in and out of the tensioner body.
3. Release ratchet pawl and push inward on plunger. It should remain locked in position and not move inward.





4. Measure free length of tensioner spring. Replace spring if excessively worn.

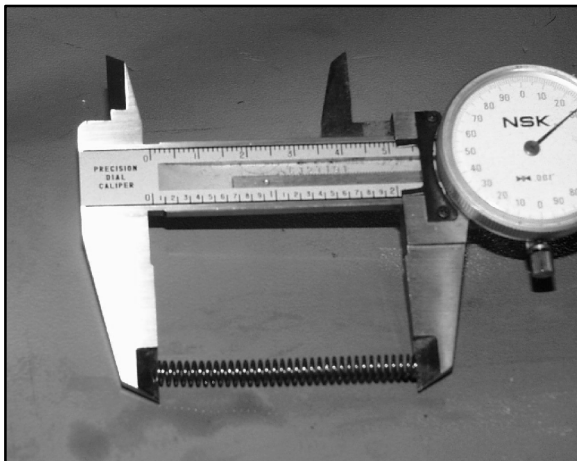

**Tensioner Spring Free Length:**  
 2.06" (5.23 cm) Std.  
 1.92" (4.88 cm) Limit

5. Replace entire tensioner assembly if any part is worn or damaged.

## ROCKER ARM/SHAFT INSPECTION

1. Remove rocker cover.
2. Mark or tag rocker arms to keep them in order for assembly.

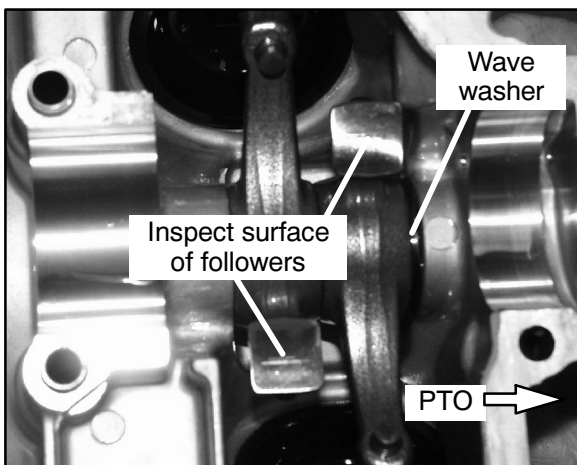

3. Inspect each rocker arm cam follower surface. If there is any damage or uneven wear, replace the rocker arm. **NOTE:** Always inspect camshaft lobe if rocker arms are worn or damaged.

4. Remove cylinder block plug using a 14 mm hex head wrench.

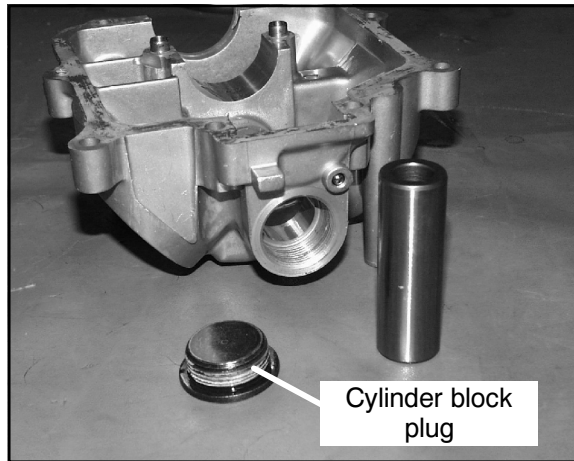

5. Measure O.D. of rocker shaft. Inspect it for wear or damage. Compare to specifications.



**Rocker Shaft O.D.:**  
 .8656-.8661" (21.987-22.0 mm)

6. Measure I.D. of each rocker arm and compare to specifications.

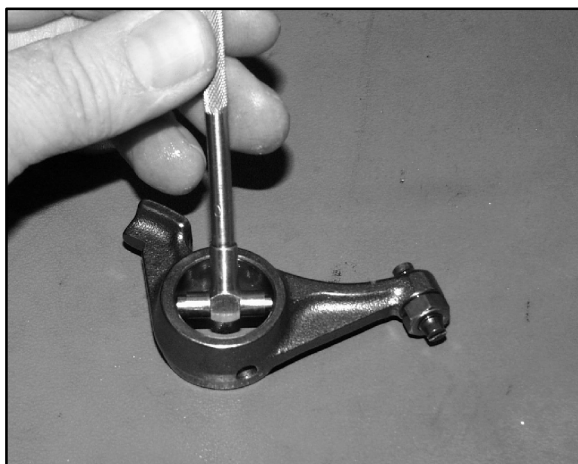

**Rocker Arm & Support I.D.:**  
.8669-.8678" (22.020-22.041 mm)

7. Measure I.D. of both rocker arm shaft support areas and visually inspect surface. Compare to specifications.

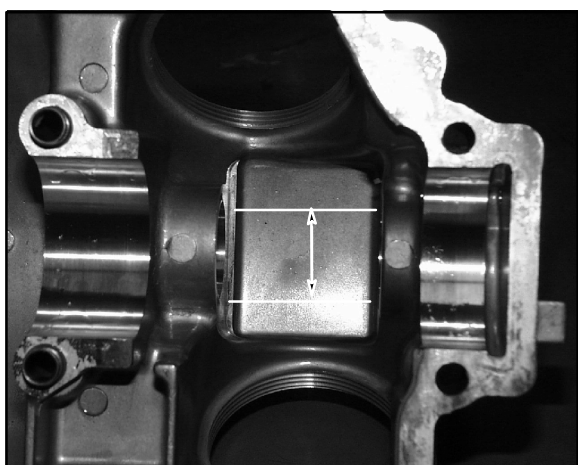

**Rocker Shaft Oil Clearance:**  
Std: .0008-.0021" (.020-.054 mm)  
Limit: .0039" (.10 mm)

8. Inspect rocker adjuster screws for wear, pitting, or damage to threads of the adjuster or locknut. Replace all worn or damaged parts. **NOTE:** The end of the adjuster screw is hardened and cannot be ground or re-faced.

## CAMSHAFT REMOVAL

1. Remove cam shaft end plug (A).

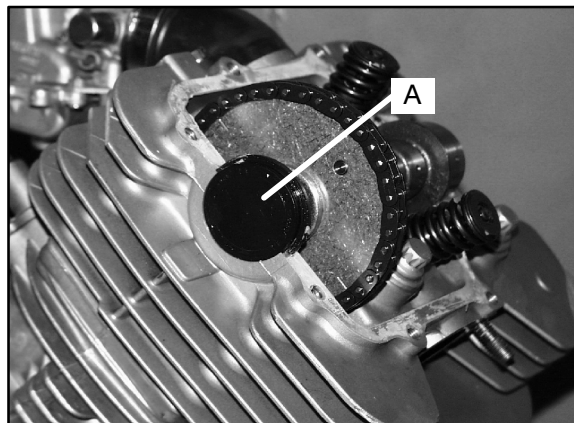

2. Remove camshaft sprocket flange bolt and washer.

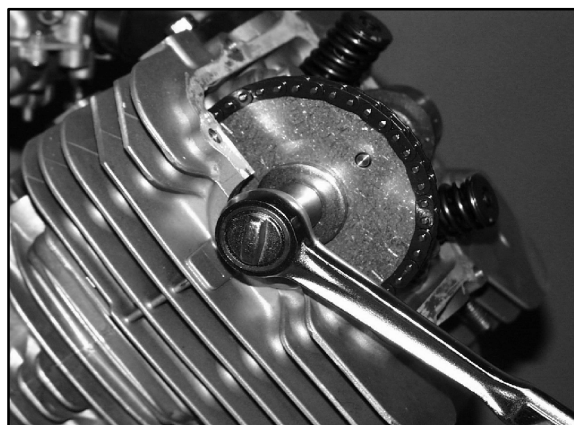

3. Place a clean shop towel in the area below cam chain sprocket.

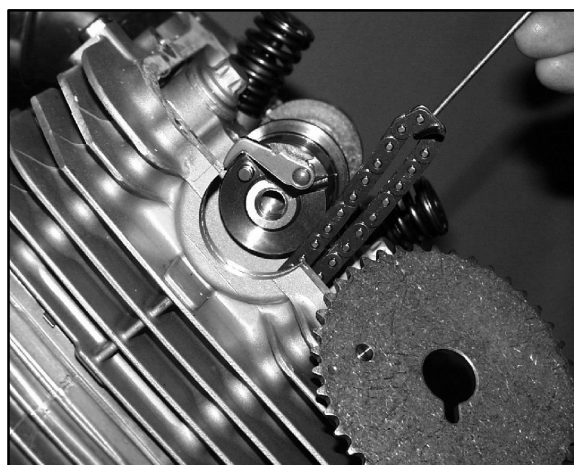

4. Remove sprocket from camshaft and chain.  
5. Secure cam chain with a wire to prevent it from falling into the crankcase.



**CAMSHAFT REMOVAL CONT'D**

6. Inspect cam sprocket teeth for wear or damage. Replace if necessary.

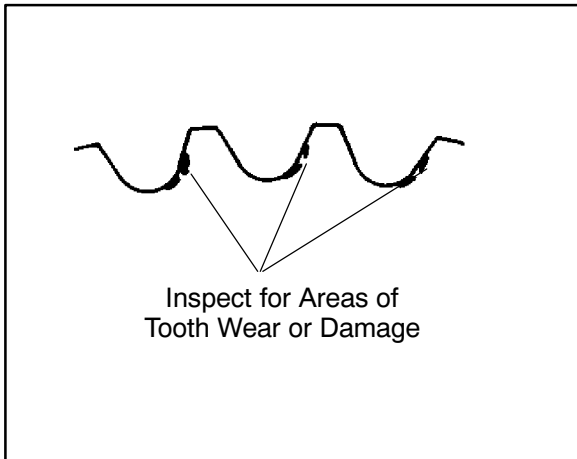

7. Remove camshaft.

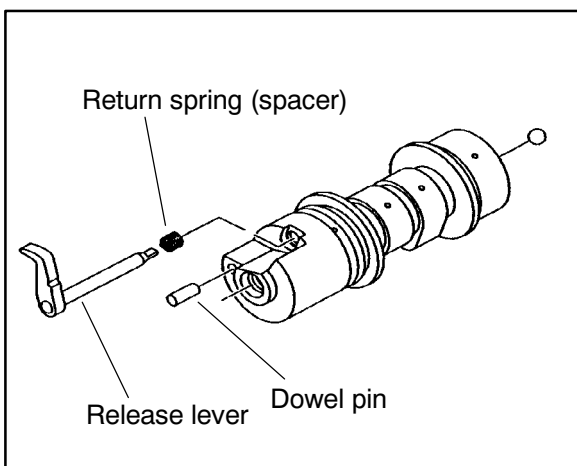

**AUTOMATIC COMPRESSION RELEASE REMOVAL/INSPECTION**

**NOTE:** The automatic compression release mechanism can be inspected and serviced without removing the camshaft from the cylinder head.

1. Check release lever shaft for smooth operation throughout the entire range of rotation.

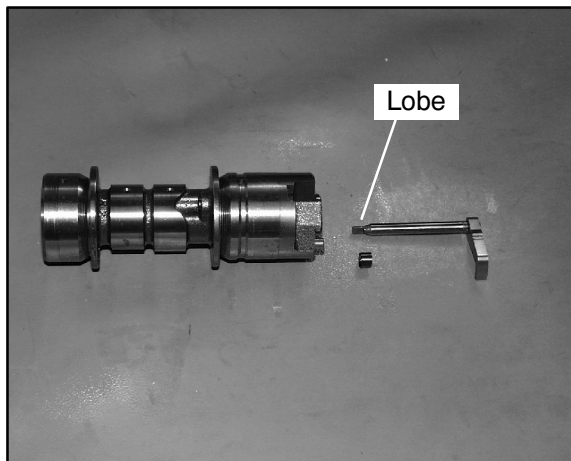

2. Remove release lever shaft and return spring (spacer).
3. Inspect shaft for wear or galling.
4. Inspect lobe on end of release lever shaft for wear and replace if necessary.

**AUTOMATIC COMPRESSION RELEASE INSTALLATION**

1. Slide spring onto shaft.
2. Apply engine oil to release lever shaft.

**CAMSHAFT INSPECTION**

1. Visually inspect each cam lobe for wear, chafing or damage.

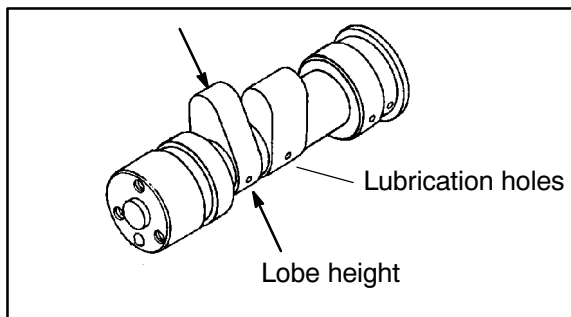

Cam Lobe Height	
<b><u>Intake</u></b>	
Std:	1.3001-1.3041" (33.023-33.123 mm)
Limit:	1.2883" (32.723 mm)
<b><u>Exhaust</u></b>	
Std:	1.3007-1.3047" (33.039-33.139 mm)
Limit:	1.2889" (32.739 mm)



2. Thoroughly clean the cam shaft, making sure the oil feed holes are not obstructed.
3. Measure height of each cam lobe using a micrometer. Compare to specifications.
4. Measure camshaft journal outside diameter (O.D.)

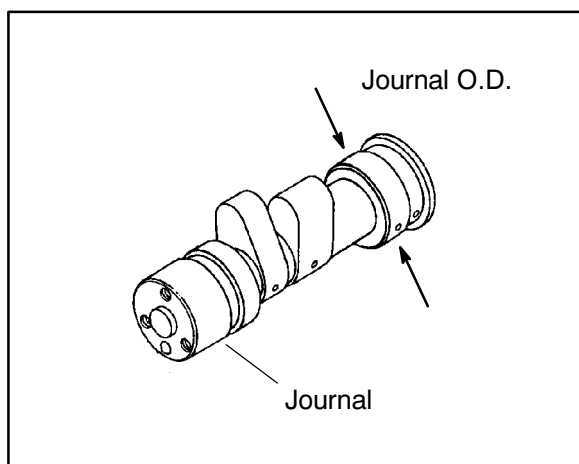

**Camshaft Journal O.D.:**  
**Mag & PTO End: 1.4935-1.4941"**  
**(37.935-37.950 mm)**

5. Measure ID of camshaft journal bore.

**Camshaft Journal I.D.:**  
**Mag & PTO End: 1.4963-1.4970"**  
**(38.005-38.025 mm)**

6. Calculate oil clearance by subtracting journal OD from journal bore ID. Compare to specifications.

**Camshaft Oil Clearance:**  
**Std: .0022-.0035" (.055-.090 mm)**  
**Limit: .0039" (.10 mm)**

Replace camshaft if damaged or if any part is worn past the service limit.

Replace cylinder head if camshaft journal bore is damaged or worn excessively.

## CYLINDER HEAD REMOVAL

1. Loosen each of the four cylinder head bolts evenly 1/8 turn each time in a cross pattern until loose.

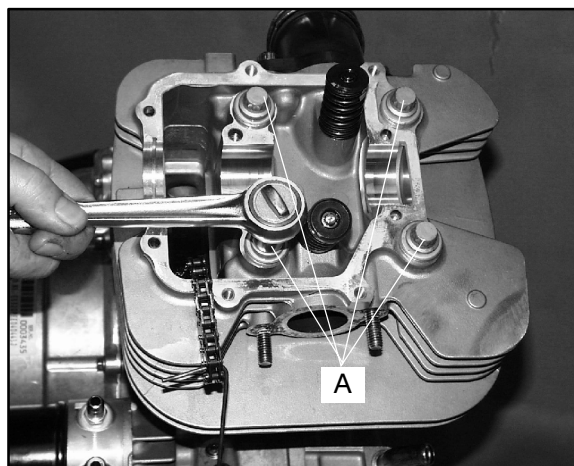

2. Remove bolts (A) and tap cylinder head lightly with a plastic hammer until loose. **CAUTION:** Tap only in reinforced areas or on thick parts of cylinder head casting to avoid damaging casting.
3. Remove cylinder head and head gasket.



## CYLINDER HEAD INSPECTION

1. Thoroughly clean cylinder head surface to remove all traces of gasket material and carbon. **CAUTION:** Use care not to damage sealing surface.



## CYLINDER HEAD WARPAGE

1. Lay a straight edge across the surface of the cylinder head at several different points and measure warpage by inserting a feeler gauge between the straight edge and the cylinder head surface. If warpage exceeds the service limit, replace the cylinder head.

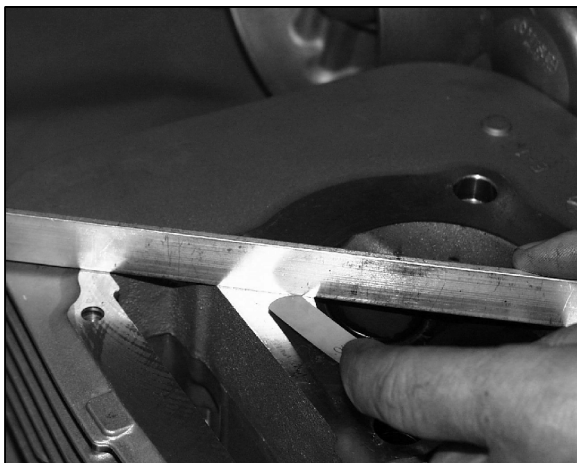

**Cylinder Head Warpage Limit:**

**.002" (.05mm)**

## CYLINDER HEAD DISASSEMBLY

**WARNING:** Wear eye protection or a face shield during cylinder head disassembly and reassembly.

**NOTE:** Keep all parts in order with respect to their location in the cylinder head.

1. Using a valve spring compressor, compress the valve spring and remove the split keeper. **NOTE:** To prevent loss of tension, do not compress the valve spring more than necessary.

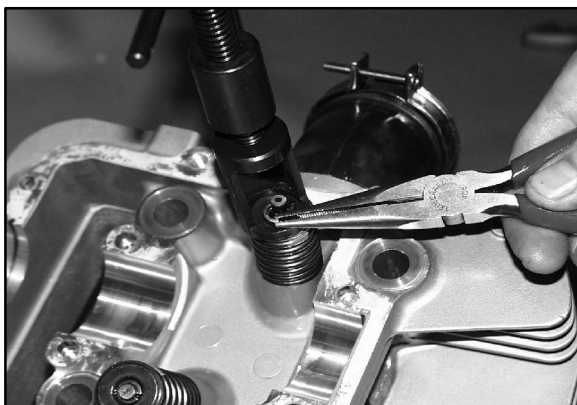

2. Remove spring retainer and spring.

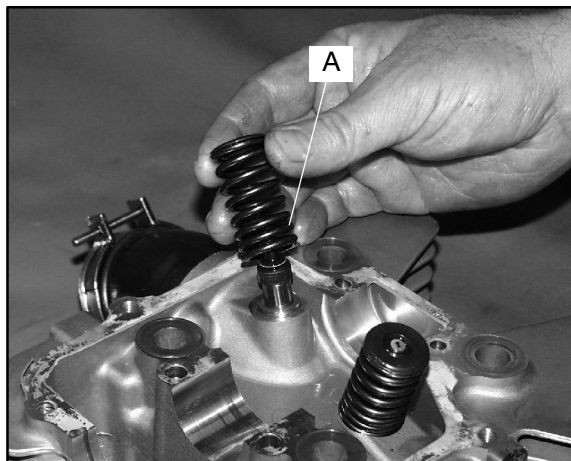

**NOTE:** The valve springs should be positioned with the tightly wound coils against the cylinder head on progressively wound springs (A).

3. Push valve out, keeping it in order for reassembly in the same guide.
4. Measure free length of spring with a Vernier caliper, III.1. Check spring for squareness as shown in III.2. Compare to specifications. Replace spring if either measurement is out of specification.

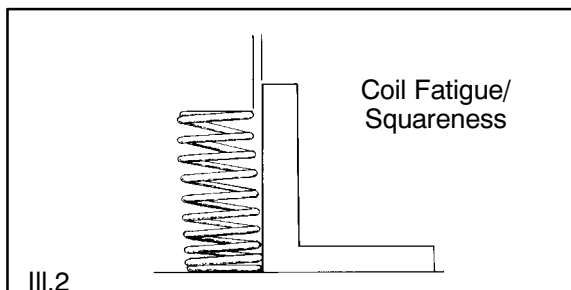
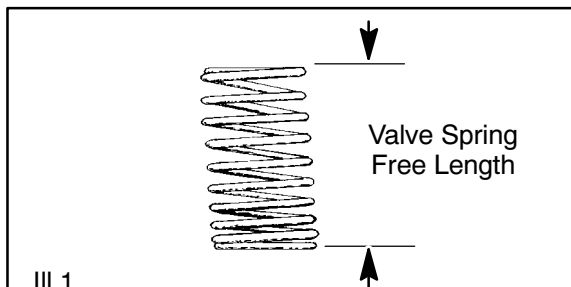

**Valve Spring Length:**

**Std: 1.673" (42.5 mm)**

**Squareness:**

**.075" (1.9 mm)**



- Remove valve seals. **CAUTION:** Replace seals whenever the cylinder head is disassembled. Hardened, cracked or worn valve seals will cause excessive oil consumption and carbon buildup.

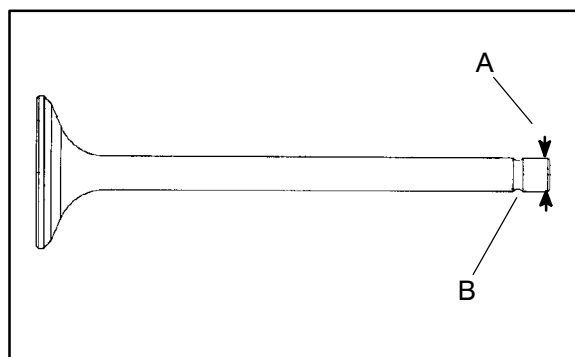

- Inspect split keeper groove for wear or flaring of the keeper seat area (B). **NOTE:** The valves cannot be re-faced or end ground. They must be replaced if worn, bent, or damaged.
- Measure diameter of valve stem with a micrometer in three places and in two different directions (six measurements total). Compare to specifications.

## VALVE INSPECTION

- Remove all carbon from valve with a soft wire wheel.
- Check valve face for runout, pitting, and burnt spots. To check for bent valve stems, mount valve in a drill or use "V" blocks and a dial indicator.

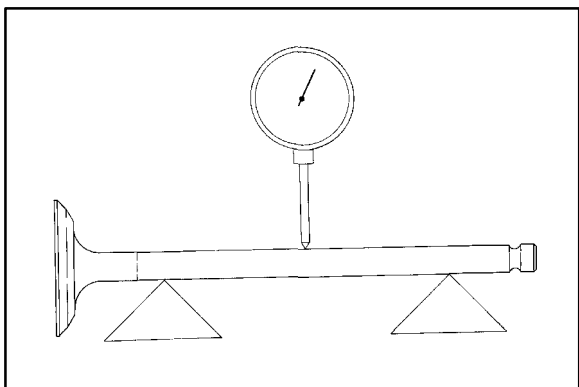

- Check end of valve stem for flaring, pitting, wear or damage (A).

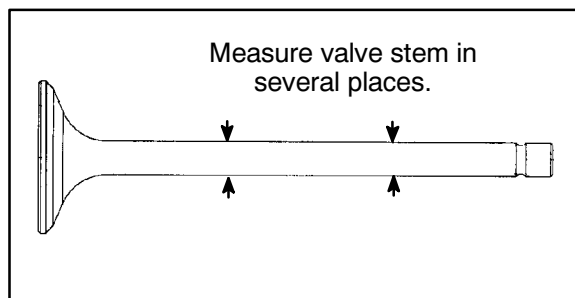

### Valve Stem Diameter:

Intake: .2343-.2348" (5.950-5.965 mm)  
Exhaust: .2341-.2346" (5.945-5.960 mm)

- Measure valve guide inside diameter at the top middle and end of the guide using a small hole gauge and a micrometer. Measure in two directions, front to back and side to side.

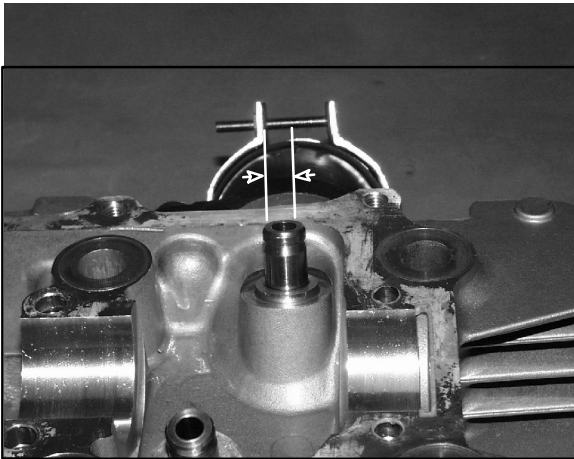

7. Subtract valve stem measurement to obtain stem to guide clearance. **NOTE:** Be sure to measure each guide and valve combination individually.
8. Replace valve and/or guide if clearance is excessive. Compare to specifications.

**Valve Guide I.D.:**  
**.2362-.2367" (6.0-6.012 mm)**

**NOTE:** If valve guides are replaced, valve seats must be reconditioned. Refer to Valve Seat Reconditioning for procedure.

## COMBUSTION CHAMBER

Clean all accumulated carbon deposits from combustion chamber and valve seat area with a soft wire brush.

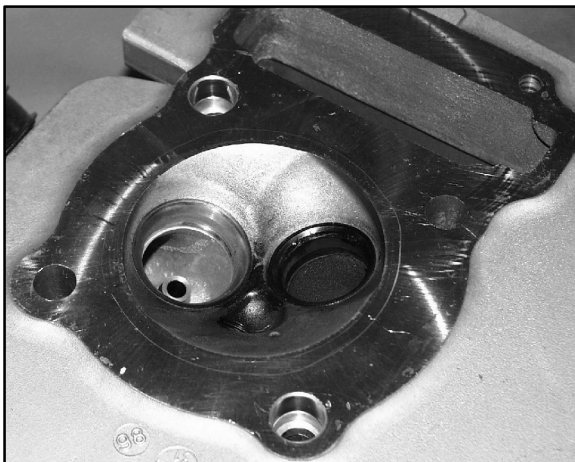

## VALVE SEAT RECONDITIONING

### Valve Seat Inspection

Inspect valve seat in cylinder head for pitting, burnt spots, roughness, and uneven surface. If any of the above conditions exist, the valve seat must be reconditioned. See Valve Seat Reconditioning, Page 3.19-3.21. *If the valve seat is cracked the cylinder head must be replaced.*

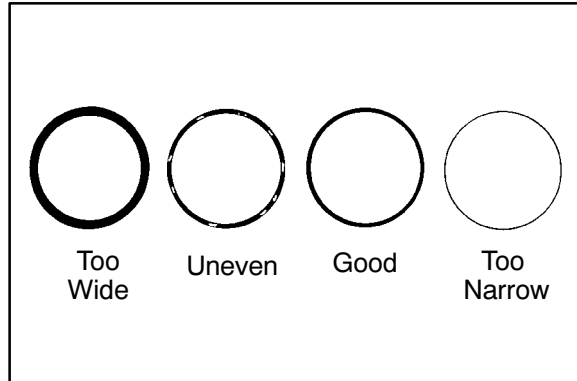

### Cylinder Head Reconditioning

**NOTE:** Servicing the valve guides and valve seats requires special tools and a thorough knowledge of reconditioning techniques. Follow the instructions provided in the Valve Seat Reconditioning Kit (PN 2200634).

**CAUTION:** Wear eye protection when performing cylinder head service. Valve guide replacement will require heating of the cylinder head. Wear gloves to prevent burns.

### Valve Guide Removal/Installation

1. Remove all carbon deposits from the combustion chamber, valve seat and valve guide area before attempting to remove valve guides. **CAUTION:** Carbon deposits are extremely abrasive and may damage the valve guide bore when guides are removed.
2. Place new valve guides in a freezer for at least 15 minutes while heating cylinder head.
3. Heat cylinder head in an oven or use a hot plate to bring cylinder head temperature to 212° F (100° C). **CAUTION:** Do not use a torch to heat cylinder head or warpage may result from uneven heating. Head temperature can be checked with a pyrometer or a welding temperature stick.



- Follow the manufacturers instructions provided with the valve seat cutters in the Valve Seat Reconditioning Kit (PN 2200634). Abrasive stone seat reconditioning equipment can also be used. Keep valves in order with their respective seat.

**NOTE:** Valve seat width and point of contact on the valve face is very important for proper sealing. The valve must contact the valve seat over the entire circumference of the seat, and the seat must be the proper width all the way around. If the seat is uneven, compression leakage will result. If the seat is too wide, seat pressure is reduced, causing carbon accumulation and possible compression loss. If the seat is too narrow, heat transfer from valve to seat is reduced and the valve may overheat and warp, resulting in burnt valves.

- Once thoroughly heated, place cylinder head on blocks of wood which will allow the old guides to be removed.
- Using valve guide driver, drive guides out of the cylinder head from the combustion chamber side. Be careful not to damage guide bore or valve seat when removing guides.
- Place cylinder head on cylinder head table.  
**NOTE:** Be sure cylinder head is still at 212° F (100° C) before installing new guides.
- Place a new guide in the valve guide installation tool and press guide in to proper depth. Check height of each guide above the cylinder head (A). Refer to specifications.  
**NOTE:** The guide can also be driven in to the proper depth. Inspect the guide closely for cracks or damage if a driver is used.

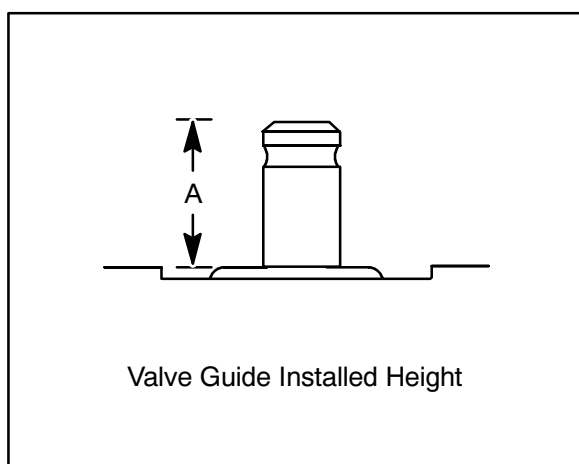

**Valve Guide Height:**  
.681-.689" (17.3-17.5 mm)

### Reaming The Valve Guide

- Allow cylinder head to cool to room temperature. Apply cutting oil to the reamer. Guides should be reamed from the valve spring side of the cylinder head. Ream each guide to size by turning the reamer clockwise continually. Continue to rotate reamer clockwise during removal of the tool.



- Clean guides thoroughly with hot soapy water and a nylon brush. Rinse and dry with compressed air. Apply clean engine oil to guides.

### VALVE SEAT RECONDITIONING

- Install pilot into valve guide.

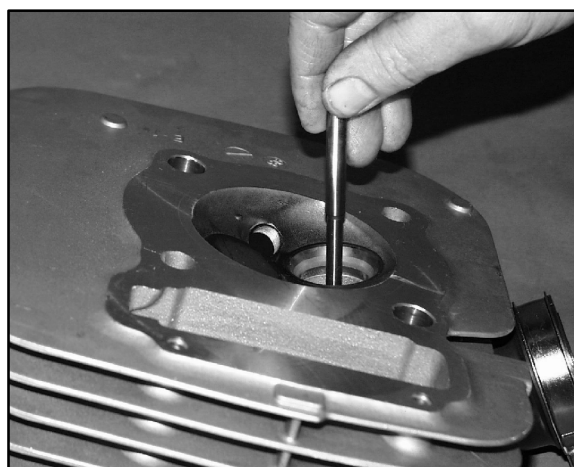

- Apply cutting oil to valve seat and cutter.





VALVE SEAT RECONDITIONING CONT'D

3. Place 46° cutter on the pilot and make a light cut.



4. Inspect the cut area of the seat.

- If the contact area is less than 75% of the circumference of the seat, rotate the pilot 180° and make another light cut.
- If the cutter now contacts the uncut portion of the seat, check the pilot. Look for burrs, nicks, or runout. If the pilot is bent it must be replaced.
- If the contact area of the cutter is in the same place, the valve guide is distorted from improper installation and must be replaced. Be sure the cylinder head is at the proper temperature and replace the guide.
- If the contact area of the initial cut is greater than 75%, continue to cut the seat until all pits are removed and a new seat surface is evident. **NOTE:** Remove only the amount of material necessary to repair the seat surface.

5. To check the contact area of the seat on the valve face, apply a thin coating of Prussian Blue™ paste to the valve seat. If using an interference angle (46°) apply black marker to the entire valve face (A).

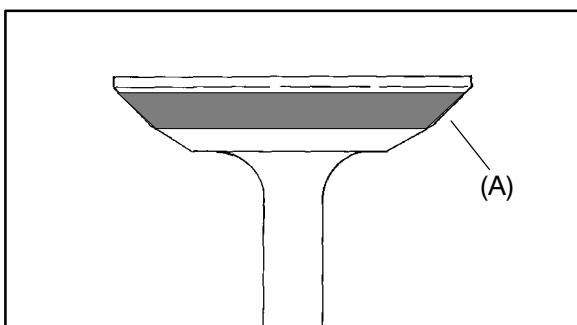

6. Insert valve into guide and tap valve lightly into place a few times.
7. Remove valve and check where the Prussian Blue™ or black marker indicates seat contact on the valve face. The valve seat should contact the middle of the valve face or slightly above, and must be the proper width (A).

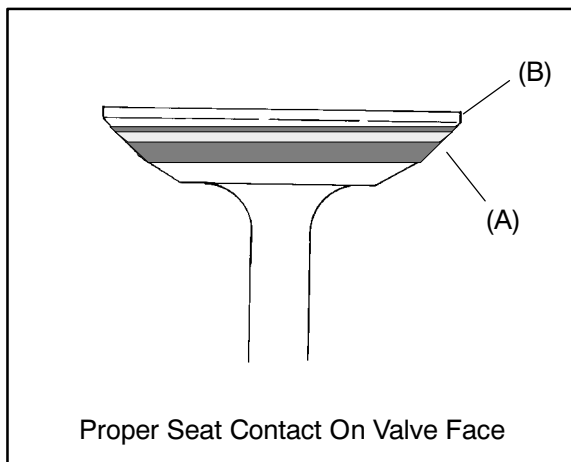

- If the indicated seat contact is at the top edge of the valve face and contacts the margin area (B) it is too high on the valve face. Use the 30° cutter to lower the valve seat.
- If too low use the 60° or 75° cutter to raise the seat. When contact area is centered on the valve face, measure seat width.
- If the seat is too wide or uneven, use both top and bottom cutters to narrow the seat.
- If the seat is too narrow, widen using the 45° cutter and re-check contact point on the valve face and seat width after each cut.

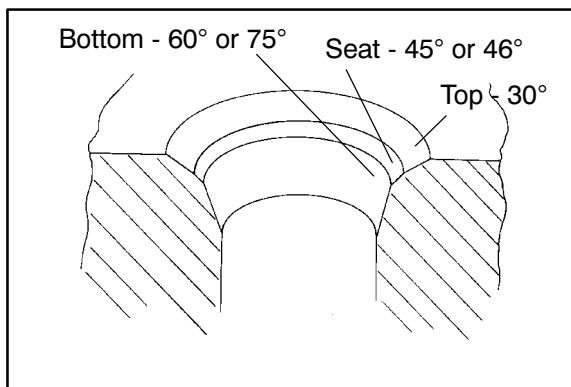



**NOTE:** When using an interference angle, the seat contact point on the valve will be very narrow, and is a normal condition. Look for an even and continuous contact point on the black marker, all the way around the valve face.

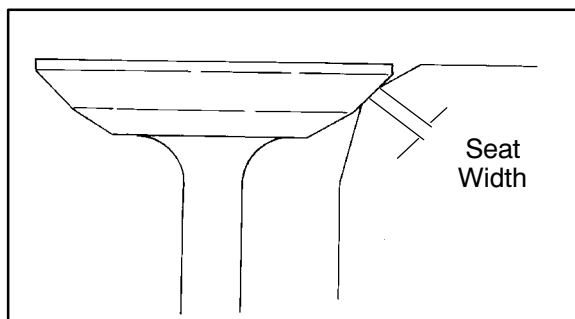

**Valve Seat Width:**

**Intake Std: .039" (1.0 mm)**  
**Limit: .055" (1.4 mm)**  
**Exhaust Std: .059" (1.4 mm)**  
**Limit: .071" (1.8 mm)**

8. Clean all filings from the area with hot soapy water, rinse, and dry with compressed air.
9. Lubricate the valve guides with clean engine oil, and apply oil or water based lapping compound to the face of the valve. Lapping is not required with an interference angle.
10. Insert the valve into its respective guide and lap using a lapping tool or a section of fuel line connected to the valve stem.

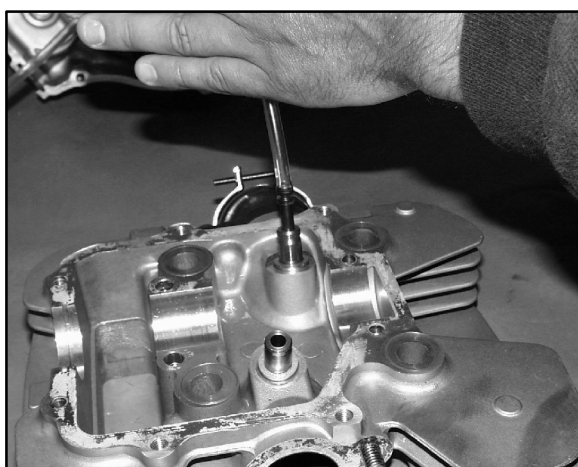

11. Rotate the valve rapidly back and forth until the cut sounds smooth. Lift the valve slightly off of the seat, rotate 1/4 turn, and repeat the lapping process. Do this four to five times until the valve is fully seated, and repeat process for the other valve.

12. Clean cylinder head, valves, and camshaft oil supply passage (A) thoroughly.



13. Spray electrical contact cleaner into oil passage and dry using compressed air.

## **CYLINDER HEAD ASSEMBLY**

**CAUTION:** Wear eye protection during assembly.

**NOTE:** Assemble the valves one at a time to maintain proper order.

1. Install new valve seals on valve guides.



2. Apply engine oil to valve guides and seats.
3. Coat valve stem with molybdenum disulfide grease.
4. Install valve carefully with a rotating motion to avoid damaging valve seal.



## CYLINDER HEAD ASSEMBLY CONT'D

5. Dip valve spring and retainer in clean engine oil and install spring with closely spaced coils toward the cylinder head.

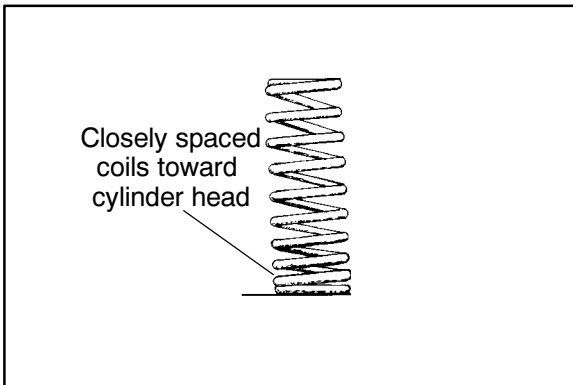

6. Place retainer on spring and install valve spring compressor. Compress spring only enough to allow split keeper installation to prevent loss of spring tension. Install split keepers with the gap even on both sides.

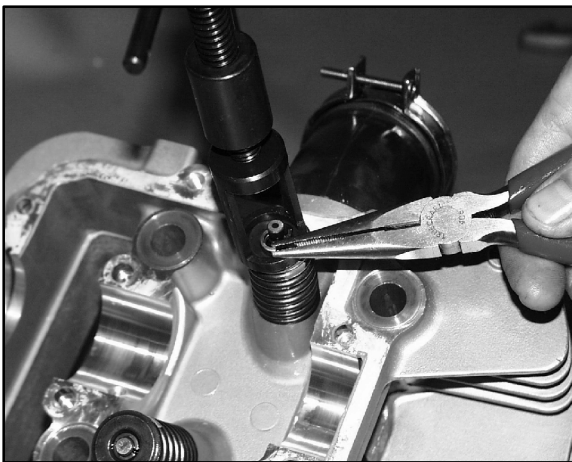

7. Repeat procedure for remaining valve.
8. When all valves are installed, tap lightly with soft faced hammer on the end of the valves to seat the split keepers.

## VALVE SEALING TEST

1. Clean and dry the combustion chamber area.
2. Pour a small amount of clean solvent into the intake port and check for leakage around each intake valve. The valve seats should hold fluid with no seepage.
3. Repeat for exhaust valves by pouring fluid into exhaust port.

## ENGINE BOTTOM END DISASSEMBLY

### Cylinder Removal

Follow engine disassembly procedures to remove valve cover, camshaft and rocker arms, and cylinder head.

1. Remove cam chain guide at front of cylinder.
2. Remove the two 6 mm cylinder base bolts.

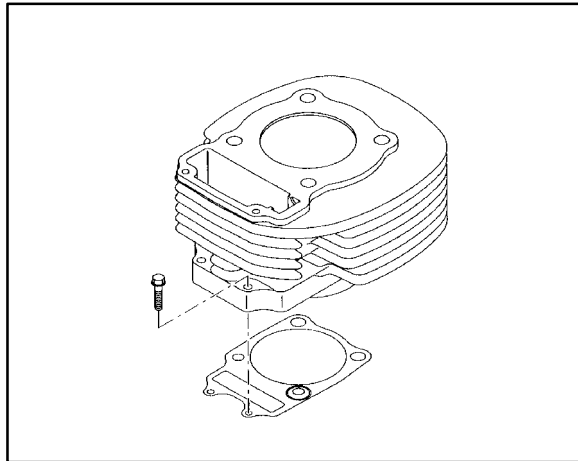

3. Tap cylinder lightly with a plastic hammer in the reinforced areas only until loose.

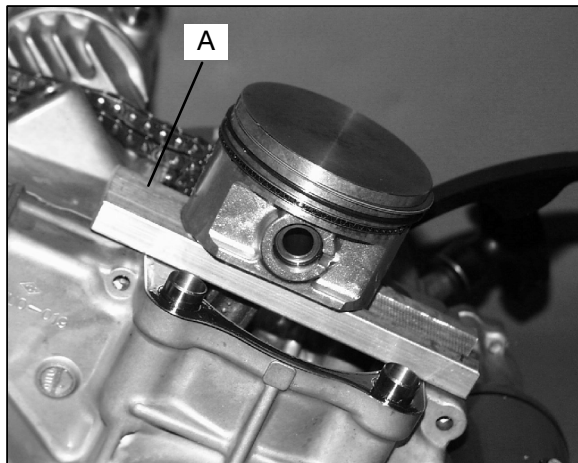

4. Rock cylinder forward and backward and lift it from the crankcase, supporting piston and connecting rod. Support piston with Piston Support Block (PN 2870390) (A).
5. Remove dowel pins from crankcase.



## PISTON REMOVAL

1. Remove circlip. Note that opening for circlip access is on the intake side.

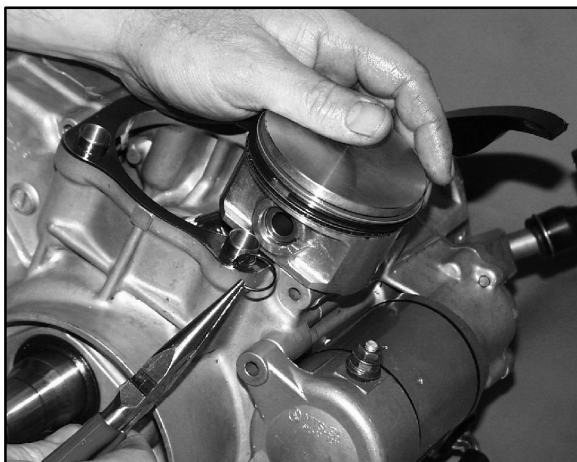

2. Remove piston circlip and push piston pin out of piston. If necessary, heat the crown of the piston *slightly* with a propane torch. **CAUTION:** Do not apply heat to the piston rings. The ring may lose radial tension.
3. Remove top compression ring.



**\*Using a piston ring pliers:** Carefully expand ring and lift it off the piston. **CAUTION:** Do not expand the ring more than the amount necessary to remove it from the piston, or the ring may break.

**\*By hand:** Placing both thumbs as shown, spread the ring open and push up on the opposite side. Do not scratch the ring lands.

4. Repeat procedure for second ring.

The oil control ring is a three piece design consisting of a top and bottom steel rail and a center expander section.

5. Remove the top rail first followed by the bottom rail.
6. Remove the expander.

## CYLINDER INSPECTION

1. Remove all gasket material from the cylinder sealing surfaces.
2. Inspect the top of the cylinder for warpage using a straight edge and feeler gauge.



### Cylinder Warpage:

.0020" (.05 mm) MAX

3. Inspect cylinder for wear, scratches, or damage.
4. Inspect cylinder for taper and out of round with a telescoping gauge or a dial bore gauge. Measure in two different directions, front to back and side to side, on three different levels (1/2" down from top, in the middle, and 1/2" up from bottom).

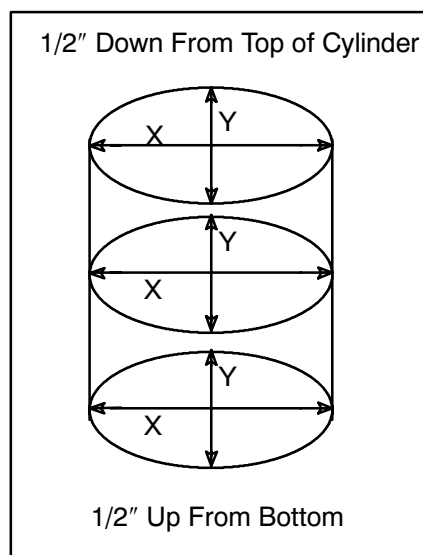



**CYLINDER INSPECTION CONT'D**

- Record measurements. If cylinder is tapered or out of round beyond .002, the cylinder must be re-bored oversize, or replaced.

**Cylinder Taper  
Limit: .002 Max.  
Cylinder Out of Round  
Limit: .002 Max.**

**Standard Bore Size:  
3.0906-3.0913" (78.50-78.520 mm)**

**PISTON INSPECTION**

- Measure piston outside diameter at a point 5 mm up from the bottom of the piston at a right angle to the direction of the piston pin.

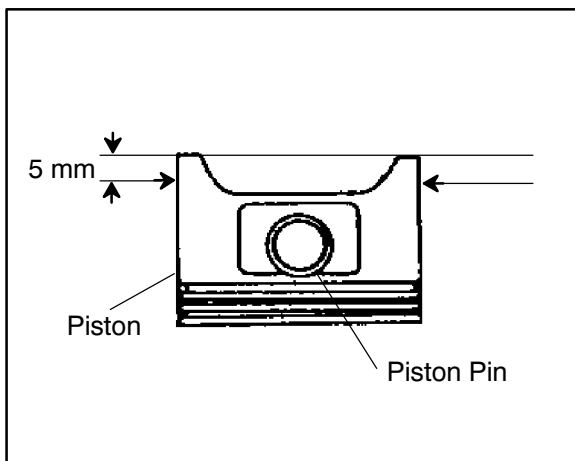

- Subtract this measurement from the maximum cylinder measurement obtained in Step 5.

**Piston to Cylinder Clearance  
Std: .0015-.0032" (.038-.082 mm)  
Limit: .004" (.11 mm)**

**Piston O.D.:  
Std: 3.0881-3.0891" (78.438-77.462 mm)**

- Measure piston pin bore.

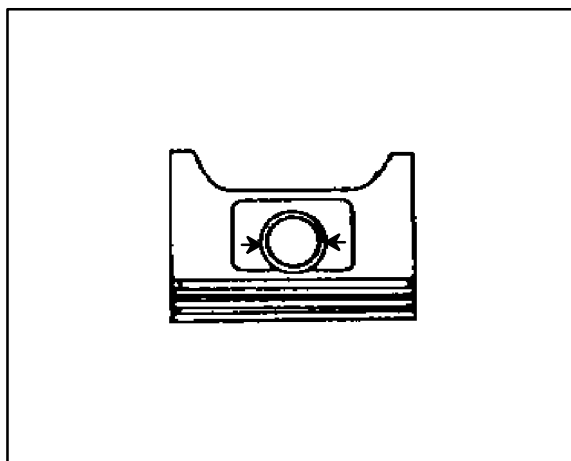

**Piston Pin Bore:  
.7095-.7097" (18.007-18.013 mm)**

- Measure piston pin O.D. Replace piston and/or piston pin if out of tolerance.

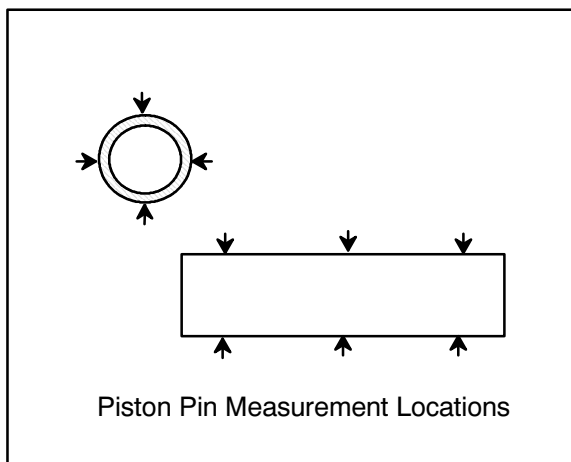

**Piston Pin O.D.  
.7092-.7095" (18.001-18.007 mm)**



5. Measure connecting rod small end I.D.

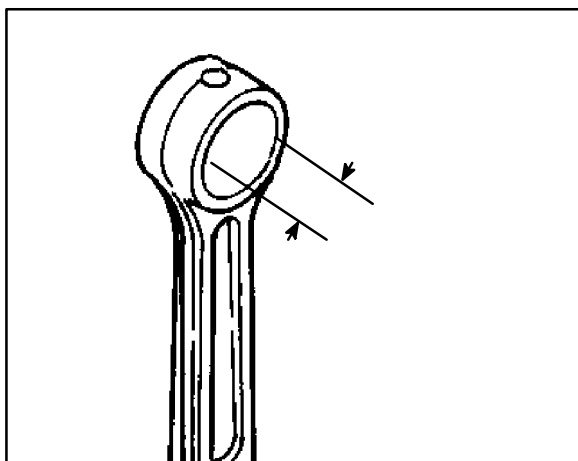

**Connecting Rod Small End I.D.**  
**.7095-.7101" (18.007-18.023 mm)**

6. Measure piston ring to groove clearance by placing the ring in the ring land and measuring with a thickness gauge. Replace piston and rings if ring-to-groove clearance exceeds service limits.

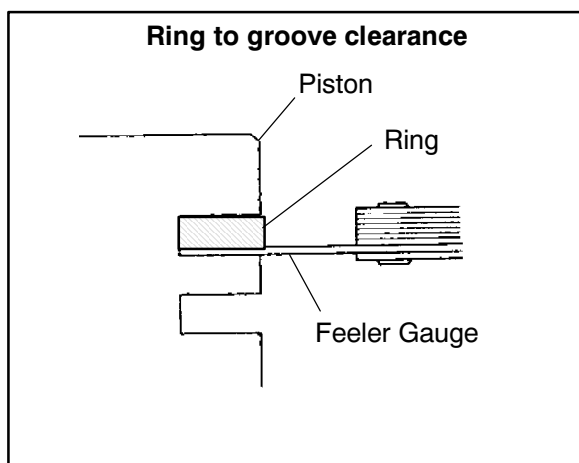

**Piston Ring-to-Groove Clearance**

**Top Ring Std: .0014-.0030" (.035-.075 mm)**  
**Limit: .0059" (.15 mm)**  
**Second Ring Std: .0010-.0026" (.025-.065 mm)**  
**Limit: .0059" (.15 mm)**

## PISTON RING INSTALLED GAP

1. Place each piston ring inside cylinder using piston to push ring squarely into place as shown.

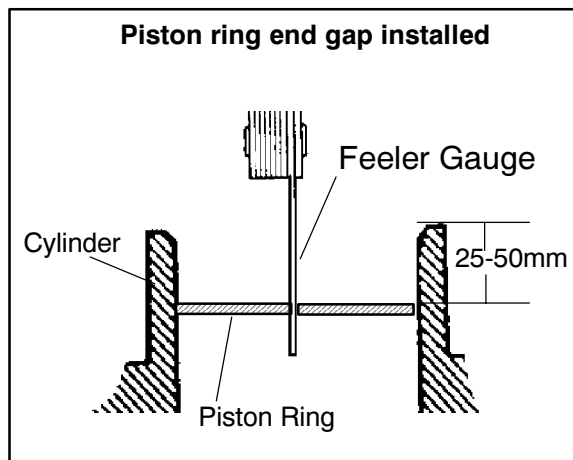

2. Measure installed gap with a feeler gauge at both the top and bottom of the cylinder.  
**NOTE:** A difference in end gap indicates cylinder taper. The cylinder should be measured for excessive taper and out of round.
3. If the *bottom* installed gap measurement exceeds the service limit, replace the rings.

**NOTE:** Always check piston ring installed gap after re-boring a cylinder or when installing new rings. A re-bored cylinder should always be scrubbed thoroughly with hot soapy water, rinsed, and dried completely. Wipe cylinder bore with an oil rag immediately to remove residue and prevent rust.

**Piston Ring Installed Gap**

**Top Ring**  
**Std: .0079-.0138" (.20-.36 mm)**  
**Limit: .039" (1.0 mm)**  
**Second Ring**  
**Std: .0138-.0197" (.35-.50 mm)**  
**Limit: .039" (1.0 mm)**  
**Oil Ring**  
**Std: .0079-.0276" (.20-.70 mm)**  
**Limit: .059" (1.5 mm)**

## CRANKCASE DISASSEMBLY

**NOTE:** The recoil starter, starter motor, starter drive, flywheel, stator, cam chain and sprockets can be serviced with the engine in the frame.



## STARTER DRIVE REMOVAL/INSPECTION

1. Remove recoil housing bolts and remove housing.

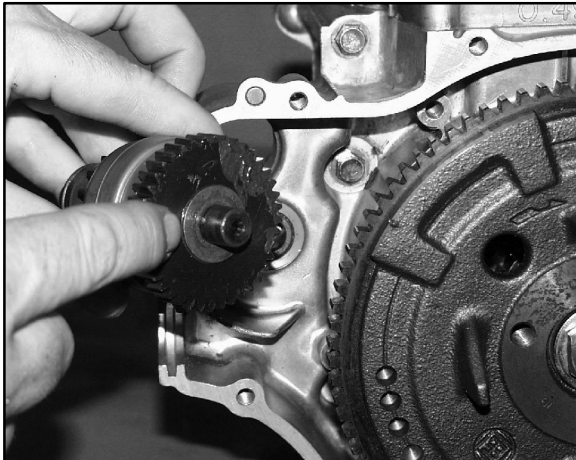

2. Remove starter drive assembly. Note the thrust washer located at the rear of the drive mechanism.
3. Inspect the thrust washer for wear or damage and replace if necessary.
4. Measure the OD of the starter drive shaft on both ends and record.

**Std. Bushing ID:**  
.4735"-.4740" (11.11-12.04 mm)

**Std. Shaft OD:**  
.470"-.472" (11.93-11.99 mm)

5. Measure the ID of the bushing in the recoil housing (A) and in the crankcase and record. Measure in two directions 90° apart to determine if bushing is out of round. Calculate bushing clearance. Replace bushing if clearance exceeds the service limit.

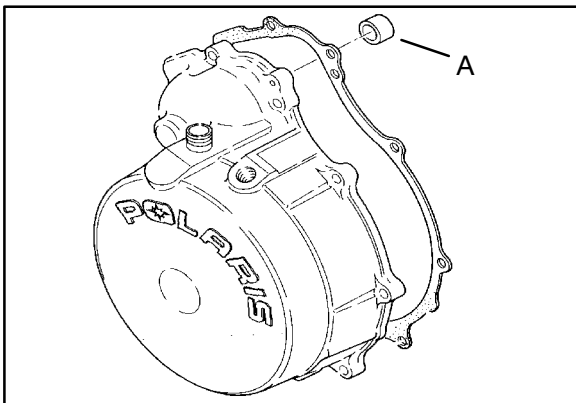

**Starter Drive Bushing Clearance:**  
Std: .0015"-.004" (.038-.102 mm)

**Service Limit:**  
008" (.203 mm)

6. Inspect gear teeth on starter drive. Replace starter drive if gear teeth are cracked, worn, or broken.

## FLYWHEEL/STATOR REMOVAL/INSPECTION

1. Remove flywheel nut and washer.

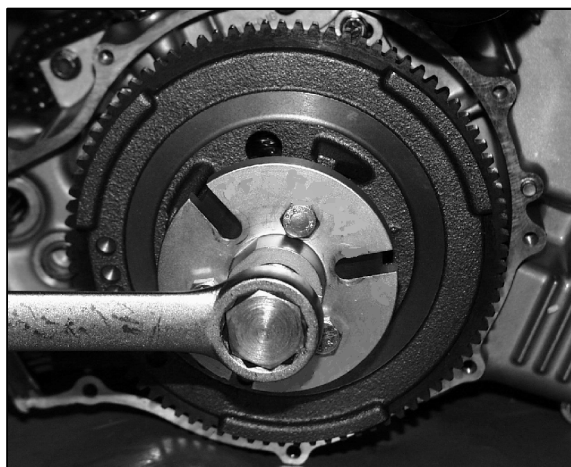

2. Install Flywheel Puller (PN 2871043) and remove flywheel. **CAUTION:** Do not thread the puller bolts into the flywheel more than 1/4" or stator coils may be damaged.
3. Mark or note position of stator plate on crankcase.



4. Remove bolts and carefully remove stator assembly, being careful not to damage crankshaft bushing on stator plate.